

EVERLAST

POWER i-MIG 253DPi

A Digitally-Controlled Synergic Pulse MIG with Stick Function



Operator's Manual for the Power i-MIG 253DPi Safety, Setup and General Use Guide

everlastwelders.com

Rev. 1 0 10613-18

Specifications and Accessories subject to change without notice.



1-877-755-9353

329 Littlefield Ave. South San Francisco, CA 94080 USA

TABLE OF CONTENTS

Section.....	Page
Letter to the Customer	3
Everlast Contact Information.....	4
Safety Precautions.....	5
Introduction and Specifications.....	9
Overview of Parameters and Specifications.....	9
Technical Parameters.....	10
General Description, Purpose and Features.....	11
Set Up Guide and Component Identification.....	12
Suggested Settings.....	12
Connections and Polarity.....	16
General Polarity and Amp Recommendations....	15
Installing The Wire Spool.....	17
Front View Main Panel.....	18
Front Panel Item Description and Explanation....	19
Side View	27
Side View Item Description and Explanation.....	28
Rear View Back Panel.....	29
Rear Panel Item Description and Explanation....	30
Basic MIG Operation.....	32
Pulse MIG Operation.....	40
MIG Control Features.....	50
Background Settings.....	49
Pulse MIG Work Sheets.....	51
Stick Operation.....	60
General Notes Concerning Operation.....	53
24 Series MIG Torch.....	61
36 Series MIG Torch.....	62
Trouble Shooting.....	64

Dear Customer,

THANKS! You had a choice, and you bought an Everlast product. We appreciate you as a valued customer and hope that you will enjoy years of use from your welder.

Please go directly to the Everlast website to register your unit and receive your warranty information. Your unit registration is important should any information such as product updates or recalls be issued. It is also important so that we may track your satisfaction with Everlast products and services. If you are unable to register by website, contact Everlast directly through the sales department at the main customer service number in your country. Your unit's warranty will be registered and in full effect. Keep all information regarding your purchase, including date of purchase and receipt. **In the event of a problem with your unit or other issue you must contact technical support before your welder can be a candidate for warranty service and returned. An over-the-phone review/diagnosis must be performed BEFORE a RMA will be issued or before the unit can be sent in for service.**

Please read the warranty statement published online and other important information found on the Everlast website of the division located in or nearest to your country. This includes the terms of the purchase and warranty procedure. Print it for your records and become familiar of its terms and conditions. Please note that Guns, accessories and torches are covered under a separate, shorter warranty. Please be sure you visit the website and are familiar with all the warranty terms before you call for service.

Everlast offers full technical support, in several different forms. We have online support available through email, and a welding support forum designed for our customers and non-customers to interact with each other. Technical advisors are active on the forum daily. We also divide our support into two divisions: technical and welding performance. Should you have an issue or question concerning your unit, please contact performance/technical support available through the main company headquarters available in your country. This support is free to all Everlast customers. For best service call the appropriate support line and follow up with an email, especially during weekends, holidays or any off hours when you cannot reach a live person. In the event you do not reach a live person, leave a message and your call will normally be returned within 24 hours, except for weekends and holidays. Also, for quick answers to your basic questions, join the company owned forum available through the website. You'll find knowledgeable staff available to answer your questions. You also may find a topic that already addresses your question at <http://www.everlastgenerators.com/forums/>. Should you need to call or write, always know your model name, purchase date and welder manufacturing inspection date. This will assure the quick and accurate customer service. **REMEMBER: Be as specific and informed as possible. Technical and performance advisors rely upon you to carefully describe the conditions and circumstances of your problem or question. Take notes of any issues as best you can. You may be asked many questions by the advisors to clarify problems or issues that may seem very basic. However, diagnosis procedures MUST be followed to begin the warranty process. Advisors can't assume anything (even with experienced users) and must cover all aspects to properly diagnose the problem. Depending upon your issue, it is advisable to have basic tools handy such as screwdrivers, wrenches, pliers, and even an inexpensive test meter with volt/ohm functions before you call.**

Let us know how we may be of service to you should you have any questions.

Sincerely,

Everlast Customer Service



Serial number: _____
Model number: _____
Date of Purchase: _____

Contact Information

Everlast US:
Everlast consumer satisfaction email: sales@everlastwelders.com
Everlast Website: everlastwelders.com
Everlast Technical Support: tech@everlastwelders.com or support@everlastwelders.com
Everlast Support Forum: <http://www.everlastgenerators.com/forums/index.php>
Main toll free number: **1-877-755 WELD (9353) 9am—5pm PST M-F**
11am-4pm PST Sat.

FAX: 1-650-588-8817

Everlast Canada:
Everlast consumer satisfaction email: sales@everlastwelders.ca
Everlast Website: everlastwelders.ca
Everlast Technical Support: sales@everlastwelders.ca
Telephone: 905-630-8246 9am-4:30pm EST M-F
10am-1pm EST Sat.

FAX: 1-905-639-2817

Everlast Australia:
Sydney: 5A Karloo Parade Newport NSW 2106
(02) 9999 2949
Port Macquarie: 2B Pandorea Place Port Macquarie
(02) 6584 2037
After hours support: **0410 661 334**
Everlast Technical Support: support@pickproducts.com

OTHER (Please record here for your records):

Safety Precautions

Everlast is dedicated to providing you with the best possible equipment and service to meet the demands of the welding applications that you have. We want to go beyond delivering a satisfactory product to you. That is the reason we offer free North American based technical support to assist you with your needs should an occasion occur. With proper use and care your product should deliver years of trouble free service.



Safe operation and proper maintenance is your responsibility.

We have compiled this operator's manual to instruct you in basic safety, operation and maintenance of your Everlast product to give you the best possible experience. Overall, welding requires experience and common sense to obtain the best results in the safest manner. As thorough as this welding manual may be, it cannot substitute for the time, instruction and knowledge level required to learn how to weld. Exercise extreme caution and care in all activities related to welding or cutting. Your safety, health and even life depends upon it. While an accident is never planned, preventing an accident requires careful planning.

Please read this manual carefully before you operate your Everlast unit. Do not operate this welder until you are thoroughly familiar with its safe and proper operation. If you feel you need more information please contact Everlast.

The warranty does not cover improper use, maintenance or consumables. Accessories such as guns, torches regulators, foot pedals etc. are not covered in the unit warranty. They are covered under a separate warranty. **Do not attempt to alter or defeat any piece or part of your unit, particularly any safety device.** Keep all shields and covers in place during unit operation should an unlikely failure of internal components result in the possible presence of sparks and explosions. If a failure occurs, discontinue further use until malfunctioning parts or accessories have been repaired or replaced by qualified personnel.

Please read and review all of the following safety information and warnings before use! Some information is unique to your unit and may not carry over between brands or types of welders. This is for your health and well-being.



Note on High Frequency electromagnetic disturbances:

Certain welding and cutting processes generate High Frequency (HF) waves. These waves may disturb sensitive electronic equipment such as televisions, radios, computers, cell phones, and related equipment. High Frequency may also interfere with fluorescent lights. Consult with an electrician if disturbance is noted. Sometimes, improper wire routing or poor shielding may be the cause.



HF can interfere with pacemakers. See EMF warnings in following safety section for further information. Always consult your physician before entering an area known to have welding or cutting equipment if you have a pacemaker.

Safety Precautions

These safety precautions are for protection of safety and health. Failure to follow these guidelines may result in serious injury or death. Be careful to read and follow all cautions and warnings. Protect yourself and others.



Welding and cutting processes produce high levels of ultraviolet (UV) radiation that can cause severe skin burn and damage. There are other potential hazards involved with welding such as severe burns and respiratory related illnesses. Therefore observe the following to minimize potential accidents and injury:



Use appropriate safety glasses with wrap around shields while in the work area, even under welding helmets to protect your eyes from flying sparks and debris. When chipping slag or grinding, goggles and face shields may be required.



When welding or cutting, always use an approved shielding device, with the correct shade of filter installed. Always use a welding helmet in good condition. Discard any broken or cracked filters or helmets. Using broken or cracked filters or helmets can cause severe eye injury and burn. Filter shades of no less than shade 5 for cutting and no less than shade 9 for welding are highly recommended. Shades greater than 9 may be required for high amperage welds. Keep filter lenses clean and clear for maximum visibility. It is also advisable to consult with your eye doctor should you wear contacts for corrective vision before you wear them while welding.



Do not allow personnel to watch or observe the welding or cutting operation unless fully protected by a filter screen, protective curtains or equivalent protective equipment. If no protection is available, exclude them from the work area. Even brief exposure to the rays from the welding arc can damage unprotected eyes.



Always wear hearing protection because welding and cutting can be extremely noisy. Ear protection is necessary to prevent hearing loss. Even prolonged low levels of noise has been known to create long term hearing damage. Hearing protection also further protects against hot sparks and debris from entering the ear canal and doing harm.



Always wear personal protective clothing. Flame proof clothing is required at all times. Sparks and hot metal can lodge in pockets, hems and cuffs. Make sure loose clothing is tucked in neatly. Leather aprons and jackets are recommended. Suitable welding jackets and coats may be purchased made from fire proof material from welding supply stores. Discard any burned or frayed clothing. Keep clothing away from oil, grease and flammable liquids.



Leather boots or steel toed leather boots with rubber bottoms are required for adequate foot protection. Canvas, polyester and other man made materials often found in shoes will either burn or melt. Rubber or other non conductive soles are necessary to help protect from electrical shock.



Flame proof and insulated gauntlet gloves are required whether welding or cutting or handling metal. Simple work gloves for the garden or chore work are not sufficient. Gauntlet type welding gloves are available from your local welding supply companies. Never attempt to weld with out gloves. Welding with out gloves can result in serious burns and electrical shock. If your hand or body parts comes into contact with the arc of a plasma cutter or welder, instant and serious burns will occur. **Proper hand protection is required at all times when working with welding or cutting machines!**



This welder contains moving parts that can result in injury. Keep hands, fingers, hair, and loose clothing away from the wire feeding mechanisms and fans while unit is switched on and in use. Do not attempt to defeat any safety feature. Always operate unit with guard in place on the wire feeder.

Safety Precautions



WARNING! Persons with pacemakers should not weld, cut or be in the welding area until they consult with their physician. Some pacemakers are sensitive to EMF radiation and could severely malfunction while welding or while being in the vicinity of someone welding. *Serious injury or death may occur!*



Welding and plasma cutting processes generate electro-magnetic fields and radiation. While the effects of EMF radiation are not known, it is suspected that there may be some harm from long term exposure to electromagnetic fields. Therefore, certain precautions should be taken to minimize exposure:

- Lay welding leads and lines neatly away from the body.
- Never coil cables around the body.
- Secure cables with tape if necessary to keep from the body.
- Keep all cables and leads on the same side the body.
- Never stand between cables or leads.
- Keep as far away from the power source (welder) as possible while welding.
- Never stand between the ground clamp and the torch.
- Keep the ground clamp grounded as close to the weld or cut as possible.



Welding and cutting processes pose certain inhalation risks. Be sure to follow any guidelines from your chosen consumable and electrode suppliers regarding possible need for respiratory equipment while welding or cutting. Always weld with adequate ventilation. Never weld in closed rooms or confined spaces. Fumes and gases released while welding or cutting may be poisonous. Take precautions at all times.

Any burning of the eyes, nose or throat are signs that you need to increase ventilation.

- Stop immediately and relocate work if necessary until adequate ventilation is obtained.
- Stop work completely and seek medical help if irritation and discomfort persists.



WARNING! Do not weld on galvanized steel, stainless steel, beryllium, titanium, copper, cadmium, lead or zinc without proper respiratory equipment and or ventilation.



WARNING! This product when used for welding or cutting produces fumes and gases which contains chemicals known to the State of California to cause birth defects and in some cases cancer.

(California Safety and Health Code §25249.5 *et seq.*)



WARNING! Do not weld or cut around Chlorinated solvents or degreasing areas. Release of Phosgene gas can be deadly. Consider all chemicals to have potential deadly results if welded on or near metal containing residual amounts of chemicals.



Keep all cylinders upright and chained to a wall or appropriate holding pen. Certain regulations regarding high pressure cylinders can be obtained from OSHA or local regulatory agency. Consult also with your welding supply company in your area for further recommendations. The regulatory changes are frequent so keep informed.



All cylinders are a potential explosion hazard. When not in use, keep capped and closed. Store chained so that overturn is not likely. Transporting cylinders incorrectly can lead to an explosion. Do not attempt to adapt regulators to fit cylinders. Do not use faulty regulators. Do not allow cylinders to come into contact with work piece or work. Do not weld or strike arcs on cylinders. Keep cylinders away from direct heat, flame and sparks.

Safety Precautions



WARNING! Electrical shock can kill. Make sure all electrical equipment is properly grounded. Do not use frayed, cut or otherwise damaged cables and leads. Do not stand, lean or rest on ground clamp. Do not stand in water or damp areas while welding or cutting. Keep work surface dry. Do not use welder or plasma cutter in the rain or in extremely humid conditions. Use dry rubber soled shoes and dry gloves when welding or cutting to insulate against electrical shock. Turn machine on or off only with gloved hand. Keep all parts of the body insulated from work, and work tables. Keep away from direct contact with skin against work. If tight or close quarters necessitates standing or resting on work piece, insulate with dry boards and rubber mats designed to insulate the body from direct contact.



All work cables, leads, and hoses pose trip hazards. Be aware of their location and make sure all personnel in area are advised of their location. Taping or securing cables with appropriate restraints can help reduce trips and falls.



WARNING! Fire and explosions are real risks while welding or cutting. Always keep fire extinguishers close by and additionally a water hose or bucket of sand. Periodically check work area for smoldering embers or smoke. It is a good idea to have someone help watch for possible fires while you are welding. Sparks and hot metal may travel a long distance. They may go into cracks in walls and floors and start a fire that would not be immediately visible. Here are some things you can do to reduce the possibility of fire or explosion:

- Keep all combustible materials including rags and spare clothing away from area.
- Keep all flammable fuels and liquids stored separately from work area.
- Visually inspect work area when job is completed for the slightest traces of smoke or embers.
- If welding or cutting outside, make sure you are in a cleared off area, free from dry tender and debris that might start a forest or grass fire.
- Do not weld on tanks, drums or barrels that are closed, pressurized or anything that held flammable liquid or material.



Metal is hot after welding or cutting! Always use gloves and or tongs when handling hot pieces of metal. Remember to place hot metal on fire-proof surfaces after handling. Serious burns and injury can result if material is improperly handled.



WARNING! Faulty or poorly maintained equipment can cause injury or death. Proper maintenance is your responsibility. Make sure all equipment is properly maintained and serviced by qualified personnel. Do not abuse or misuse equipment.



Keep all covers in place. A faulty machine may shoot sparks or may have exploding parts. Touching uncovered parts inside machine can cause discharge of high amounts of electricity. **Do not allow employees to operate poorly serviced equipment.** Always check condition of equipment thoroughly before start up. Disconnect unit from power source before any service attempt is made and for long term storage or electrical storms.



Further information can be obtained from The American Welding Society (AWS) that relates directly to safe welding and plasma cutting. Additionally, your local welding supply company may have additional pamphlets available concerning their products. Do not operate machinery until your are comfortable with proper operation and are able to assume inherent risks of cutting or welding.

Overview of Parameters and Features*

Power i-MIG 253DPi	
Amp Adjustment Range	10-250 Amps
Volt Adjustment Range	14-28 Volts in standard mode (Volt value becomes Offset/Trim value -5 to +5 in Synergic Pulse/Double Pulse Modes)
Wire Feed Speed	60 to 600 IPM (.5-15 m/min) Includes "Wire Jog" mode for loading or changing wire without having to dispense and waste gas.
Input Voltage	220-240V Single phase (208V permissible)
Welder Type	Digitally controlled, IGBT inverter type with Pulse CV GMAW (MIG) and CC Stick functions. Features CV Spool Gun or CV Push-Pull gun capability (Spool/Push-Pull Gun optional).
Wire Roll Size and Diameter	.030"-.045" wire diameter assortment. including select U groove (aluminum/bronze) and V groove (steel/stainless) drive rolls. Other optional sizes and types available. Equipped with 12" diameter roll capacity (30-44lb). An 8" adapter is available for use with 10-12 lb. rolls. 4" rolls not supported. (Weights referenced are for commonly sold packages of steel wire for wire diameter)
MIG Operation and Type	Synergic standard MIG and Synergic Pulse/Pulse on Pulse MIG function. Includes V Groove drive rolls for: .030" to .045" (.8mm to 1.2mm in diameter for Steel, Stainless Steel use.** Includes U groove drive rolls for: .040" to .045" (1.0mm to 1.2mm) for Aluminum, and Bronze (brazing) use. ** Additional Drive Rolls may be ordered direct from Everlast (2 pc kit). Size and type stamped on side of the drive roll next to the related groove for easy identification. Synergic Pulse settings for Mild Steel, Stainless Steel, 40XX series Aluminum, 50XX series Aluminum, and Bronze wires.
Burn Back Timer Control	.01-.5 seconds
Inductance	1-10 in whole number increments.
Pulse Frequency	Single: Synergically Controlled Double (Pulse on Pulse): .1 to 9.9 Hz
Peak Pulse Amps/Volts	Single: Synergically Controlled Voltage/Offset (Trim). Amps adjusted to suit thickness. Double: Synergically Controlled Voltage/Offset (Trim). Amps adjusted for each half cycle of pulse to create "stacking effect" of weld bead. Range 10-250V
Pulse Time On	Single: Synergically Controlled Double (Pulse on Pulse): 10-90% of Peak Pulse setting
Memory	Save and recall up to 10 programs (0-9)
MIG Burn Back Duration/Voltage	.01-.5 Seconds 5-20V (-5 to +5 Volt offset/trim value in Synergic Pulse/Double Pulse)
Hot Start	0-200
End Amps/Volts	10-250A /14-28V (-5 to 5 offset)
Torch Trigger Functions/latch	2T, 4T, 4T Special
Stick E6010 Capability	No, 6011 only
Power Cable Length	9.5 ft. (3m)
Accessories**	24 Series MIG torch 9.5 ft. (3m), Work clamp with cable 9.5 ft. (3m) 300 A Stick Torch, with cable (3m) Floating ball type regulator.

*See next page for complete electrical and technical data.

**Specifications and packaged accessories subject to change without notice.

EVERLAST POWER i-MIG 253DPi				
MODEL: POWER i-MIG 253DPi			SERIAL NO.	
			EN/ IEC60974.1	
		DC: 40-250 A; 16-30V		
		X	35%	60%
	U_0 V 80 V	I_2	250 A	195 A
		U_2	26.5 V	23.8 V
		DC: 10-200 A; 20.4-28 V		
		X	35%	60%
	U_0 V 80 V	I_2	250 A	200 A
		U_2	30V	28V
	U_1 240V 1~ 50/60 Hz	I_{1MAX} : 45.5A I_{1EFF} : 36A		
PROTECTION: IP21S	COOLING METHOD: FULL TIME, DUAL FAN		INSULATION: F	
WIRE SPEED FEED RATE*: 60-600 INCHES PER MINUTE				
EFFICIENCY: \geq 85%		POWERFACTOR: 83%		

*60 IPM is based on minimum useable feed rate.

NOTE: Environment, Maintenance and Safety: Keep this welder at least 12 inches away from all objects for proper cooling. Do not exceed 40° C in environment or duty cycle will be reduced. Regularly inspect and clean the welder and circuitry on a monthly basis with dry compressed air. Remove the covers only after the unit has been turned off and unplugged for 30 minutes to discharge the capacitors and to prevent the possibility of electrocution. Do not grind or throw sparks near the welder to prevent damage to the panel face and internal components. Damage of this nature is not covered by the warranty.

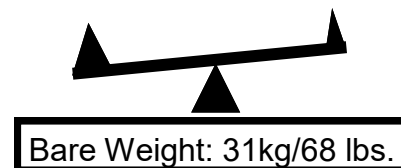

General Description, Purpose and Features. The Power i-MIG 253DPi features a Synergic Pulse and Double Pulse design to help customers meet their needs regarding new industrial and specialty MIG welding requirements in the auto and marine industries where new alloys and welding techniques are being employed. The low profile Power i-MIG 253DPi features faithful IGBT power components and an intuitive design. The design includes dual fan cooling which yields a heavy duty, industrial level 60% duty cycle performance at 250 amps maximum output not only in the MIG modes, but also in the additional Stick mode.

The Pulse MIG capability of the Power i-MIG 253DPi is designed to help the user maintain maximum control over heat and fusion. The Power i-MIG 253DPi employs a synergic single pulse and double pulse (sometimes referred to as Pulse-on-Pulse) GMAW type design that features optimized synergic control over the pulse parameters. Synergic control most simply defined, means that complicated parameters such as pulse width, frequency, pulse volts and amps are automatically controlled by pre-programmed algorithmic settings. These settings are programmed and tested by trained welding engineers at the factory for best performance. In practical terms, the synergic design needs some basic input parameters from the user to ensure proper operation. These are simple things such as wire type (alloy type/AWS classification), and wire diameter. After that, Amps (which is the same as adjusting wire speed) are input by the operator to match metal thickness. The arc length can be fine tuned if needed to match welding condition requirements. If adjustments are made to arc length, the pulse automatically adapts operation parameters to work well with the new adjustments. This makes it ideal for use with 40XX and 50XX series Aluminum, and most weldable Stainless Steels where heat and arc control is critical and out-of-position welding is regularly encountered. The synergic pulse also lends itself well to applications such as auto-body repair where the employment of high-strength, high carbon steel requires MIG brazing to meet new certification requirements and heat control restrictions mandated by auto manufacturers. To provide the best results while MIG welding aluminum, or while MIG brazing high strength steel, the unit can be equipped with the optional 300 Amp Parker® SGP-360A push-pull gun or the Parker® DSP-360A spool-gun. Both optional gun arrangements can be operated in either standard mode, or synergic modes. These additional guns are available directly from Everlast and offer the best choice for welding aluminum.

For the budget minded operation, the unit does include a special low-resistance polymer liner designed for use in the standard gun if Aluminum welding or brazing must be done without the use of either a push-pull or spool gun. **The original factory installed MIG gun liner is designed for Steel and Stainless Steel welding and must be removed and replaced with the polymer liner before welding with Aluminum and Bronze wires.** This set-up is also useful in tight or compact areas where access is restricted. **If this gun arrangement is used, the MIG gun cable must be used with the gun cable running fairly straight without coiling or looping.** Operation with optional gun lengths longer than the factory supplied standard gun with Aluminum or Bronze wires, will create wire feeding issues. If gun cable lengths longer than what is supplied with the welder is required to weld aluminum or bronze, a push-pull gun or a spool gun is going to be necessary. For Steel and Stainless Steel welding applications, longer gun lengths up to 17 feet may be used without any issue. Longer gun lengths may be used for larger diameter wires but smaller wire diameters (i.e. .023"/.6 mm) may bind or bird's nest in the feeder or in the gun liner.

In addition to the synergic Pulse-MIG functions, the Power i-MIG 253DPi features a non-pulse synergic MIG mode for basic MIG operation with 75/25 Ar/CO₂ mix or 100% CO₂, as well as an independent, manual control MIG mode. The added capability for SMAW (stick welding), makes it an excellent candidate for use in commercial fabrication shops.

This welder is designed for full-size rolls of MIG wire, 12" in diameter (up to 44 lbs. typically). A wire spool adapter is available which will allow the unit to accept 8" spools. Although after-market 4" spool adapters can be purchased from many suppliers, Everlast does not make or supply a 4" adapter for the machine. If 4" rolls are typically the way you weld Aluminum or other metals, consider purchasing the spool gun which is ideal for this type of application. When price per pound is considered, full size 12" rolls are the most economical way of welding. When using an 8" or 12" diameter roll of Aluminum or Bronze wire, a push-pull gun is recommended. The standard gun may also be fitted with the supplied polymer liner in lieu of the optional push-pull gun although more problems with wire feeding may be encountered.

For easy set-up and recall of the most commonly used settings this welder is capable of storing up to 10 pro-

grams. This is useful when multiple operators are using the same welder or when different thicknesses and metal types are changed on a frequent basis. When needing to save parameters, particularly with multiple operators, we recommend that you keep a laminated, “quick” reference list of saved program numbers associated with specific welding applications near the welder. Usually, the best place to store this is the inside of the door of the welder. To help with this, at the end of the manual we have created a list of quick reference charts that you can fill out for different applications that can be stored in a sleeve pasted on the inside door or that can be kept in a reference note book near the welder.

The unit also features a heavy-duty wire feeding mechanism with 4 driven drive rolls for maximum wire feeding capability. The 4 roll drive system reduces the chance of irregular feeding and helps reduce the “cork screwing” effect of the wire into the puddle. “Corks crewing” or Helixing (due to the cast of the wire) of the wire as it comes out of the gun can result in an unstable arc and even improper placement of the weld bead in extreme conditions. When you couple proper drive roller tension and correct drive roll selection, unintended slipping and irregular feeding can be virtually eliminated without troublesome bird’s nesting and stuttering of the wire (at start) However, if too much tension is applied to any wire feeder, bird’s nesting and even breakage of the wire (particularly the smallest wire diameters) will result if the wire encounters excessive resistance such as cold stubbing into the puddle or a contact tip burn back occurs. If you suspect either have occurred, stop welding immediately and check your drive feeder for tangled or broken wire.

See below for additional summary of features:

- 1) **GMAW Process (MIG).** The digitally-controlled MIG components precisely control arc functions and give real-time feed back about the welding output parameters. Both Single Pulse and Double Pulse modes are synergistically based and make welding in pulse modes as simple as selecting the correct amperage to match the thickness of the weld. Arc length can be “trimmed” to the desired length with the voltage offset feature. As already mentioned, the Power i-MIG 253DPi is also spool gun and push-pull gun (optional) ready for Aluminum welding or and brazing if needed. Both the spool gun and the push-pull gun unit will function in all MIG modes and with all synergic Pulse settings. The welder can
- also be used with the flux-core wire (FCAW) when equipped with optional serrated drive rolls. However, if Flux-Core is used in synergic mode and synergic Pulse modes, the welder will not operate correctly. Even with significant adjustment of trim and inductance settings, problems achieving desirable welds may be encountered. When attempting to use Flux-Core or Dual-Shielded wires, the standard mode (without the synergic function enabled) should be used for the most reliable operation.
- 2) **SMAW (Stick).** In stick mode the Power i-MIG 253DPi delivers a smooth DC low spatter arc. Professional, high-quality welds are obtainable with E7018, 7014, 309L, 316, 6011 and many specialty rods that are designed for use with any stick welder. **NOTE: This unit is not designed for E6010 use.** The Stick mode also features adjustable Hot Start intensity control which is designed to help reduce sticking during arc starts. It will also simultaneously help reduce porosity or inclusions during arc initiation. The stick arc force control adjusts the quality and feel of the welding arc. The arc force is used to adjust the amp reaction when the arc gap is shortened and voltage drops. This helps to prevent sticking of the welding rod and helps maintain the arc going as arc voltage falls. This action also boosts penetration and controls overall “feel” of the arc.
- 3) **Burn-Back Control.** The Burn-back feature is used to control the length of the wire stick-out after the trigger is released. It helps to prevent the welding wire from sticking in the coalescing weld puddle after the arc is terminated. It also saves the user from having to trim the wire before restarting the arc. Burn-Back control consists of two settings: Burn-Back time and Burn-Back Volts. Typically Burn back time is set long enough to prevent wire sticking in the weld puddle. The wire should melt back to the point where trimming is not required to restart the arc and no wire sticking is observed. Burn back time is usually adjusted to less than .1 seconds, but more time can be added as needed. Thicker wires will need longer burn back times. For a starting point in Synergic pulse modes, Burn-Back Volts (now displayed as trim/Volt offset value) should be set for a lower value than the trim/Volt offset value used for regular welding.
- 4) **Synergic MIG Operation.** The synergic welding modes are designed to simplify welder setup and adjustment. Synergic MIG welding allows the customer to input basic parameters of wire type and

wire diameter and the machine will automatically set the unit up to operate based off fully tested algorithmic settings chosen by factory welding engineers. The user only needs to adjust welding Amps to match the thickness of the metal being welded. Then unit's programming automatically sets the balance of the relevant parameters. The unit's programming allows fine tuning of the arc length and wire stick out with the use of the Voltage/Trim adjustment and Inductance control. The machine can be operated synergically in standard MIG mode, and Single Pulse Mode. For Double Pulse Mode, the half cycles are synergically adjusted (see full explanation found later in this manual in the detailed Pulse MIG explanation found later in this manual)

- 5) **Pulse MIG operation.** See full details in "Pulse MIG section".
- 6) **Adjustable Pre/Post Flow Control.** The Pre and Post-Flow control feature is designed to improve weld quality at the beginning and end of the weld where porosity and oxidation is likely to occur. Pre and post flow time is manually adjusted up or down based off of desired shielding effect to prevent porosity. Of course, the flow times can be shortened to conserve gas if pre and post weld shielding of the gas is not a concern. A short Pre-Flow time of about .3 to .5 seconds and a Post-Flow time of about 2 to 3 seconds is a reasonable starting point when employing these features. Keep in mind that a long Pre-Flow time will delay the arc start and wire will not feed the wire until the Pre-Flow time is satisfied. Add more flow time if porosity or oxidation or excessive discoloration is noticed at the beginning and end of welds. **Hold the gun in place over the cooling weld until post flow has terminated or the effect will be lost and gas will be wasted.**
- 7) **Slow Run-in of Wire.** This feature improves arc striking quality in MIG modes by helping prevent arc stuttering (machine gunning) and push-off during arc initiation by slowing the wire speed until the arc is established. Once the arc is established, the wire feed speed automatically begins to rapidly ramp up to weld at the desired wire speed/Amps. **Note: The slow run-in feature prevents the operator from taking accurate measurements of wire feed speed manually as the wire will feed slower until the arc is struck and maintained.** This is not an adjustable feature and cannot be deactivated.
- 8) **Spool Gun and Push-Pull Gun Modes.** The Power i-MIG 253DPi is well equipped to handle the aluminum welding needs of most customers by being

both spool gun and push-pull gun ready. The unit can handle several different Everlast spool gun models, but the most capable and recommended is the 300 amp, Parker® DSP 360A spool gun. However, for professional fabricating and repair needs, the Parker® SGP 360A Push-Pull Gun is an excellent choice to handle welding duties that require serious or frequent aluminum welding capability. The pull motor on the push-pull gun is synchronized with the main wire feeder in the welder cabinet to weld seamlessly with larger rolls of aluminum wire. When coupled with a push-pull gun, the pulse feature of the Power i-MIG 253DPi can greatly increase the quality and speed of out-of-position welds common in production welding applications of aluminum. **NOTE: Operation of the welder with the Push-Pull gun may require the purchase of additional Push-Pull drive rolls to match the wire diameter used. Also make sure that if welding aluminum or bronze with the push-pull gun, or the standard MIG gun, the main feeder drive rolls are changed to the U groove type and that the grooves match the diameter of the wire used. The U-shaped groove prevents deformation of the soft aluminum and bronze wire as the wire is fed. This prevents feeding problems in both the long and short terms.**

Basic Welder Design and Construction. The Power i-MIG 253DPi features an intuitive control panel and couples it with digitally controlled IGBT inverter design that produces a stable arc while conserving energy. Everlast utilizes quality components from US, European, and Asian based companies to ensure reliability and parts commonality. Major control components are a plug-and-play design which allows rapid diagnosis and a quick repair of the welder. Welding parameters can be infinitely and continuously adjusted throughout the range, offering instant welding response for maximum welding control.

Installation. The Power i-MIG 253DPi is built with both durability and convenience in mind. It is considered ideal for circumstances where portability is needed. Critical components are protected by conformal coatings to make the welder environmentally resistant and has a water ingress rating of IP21S, (the standard in the welding industry to protect from vertically dripping water). However, some common sense care should be exercised to make sure that the welder offers the safest and best performance. Please note the following items

regarding safe and proper welder operation to ensure best service and results while welding:

- 1) Do not use the welder in damp or wet areas. Perspiration and other forms of water in contact with the body can increase the risk of shock or electrocution.
- 2) Do not use the welder in extremely corrosive environments. To maintain optimum power transfer, check main connections, clamps and cables frequently to ensure that components are not corroded. Excessive dirt, corrosion and oxidation can result in an unstable arc and excessive heat build-up. If the work clamp becomes corroded or damaged, be sure to replace it with a heavy-duty work clamp rated for at least 300 amps. If your work clamp appears to become extremely hot while welding, and all connections are clean and secure, replace the work clamp.
- 3) Store the welder covered with a moisture and fire resistant material.
- 4) If used on a mobile cart, strap or fix the welder to the cart so that accidental overturn is not likely.

Duty Cycle/Overcurrent/Under Voltage/Overvoltage

Warnings. Thanks to a dual cooling fan design, the Power i-MIG 253DPi has a duty cycle rating of 60% at 250 Amps while welding in MIG mode and a rating of 60% @ 250 Amps while welding in stick mode. The duty cycle rating is the amount of time (expressed as a percentage) out of 10 minutes the unit can weld without a rest. For MIG, the unit is capable of welding 6 minutes out of every 10 minutes at the maximum output of 250 Amps. For the balance of the 10 minute period, the unit should be allowed to rest and cool while running. This

Note: If a generator is going to be used with this unit, please make sure that it is certified by its manufacturer to be “clean power,” which is normally stated as less than 5% THD (Total Harmonic Distortion). For proper operation with a generator, make sure you have at least a minimum 12,000 watts of surge capability and 8,500 watts of continuous rated output capability.

CONNECTIONS AND POLARITY

MIG*

SPOOL GUN**

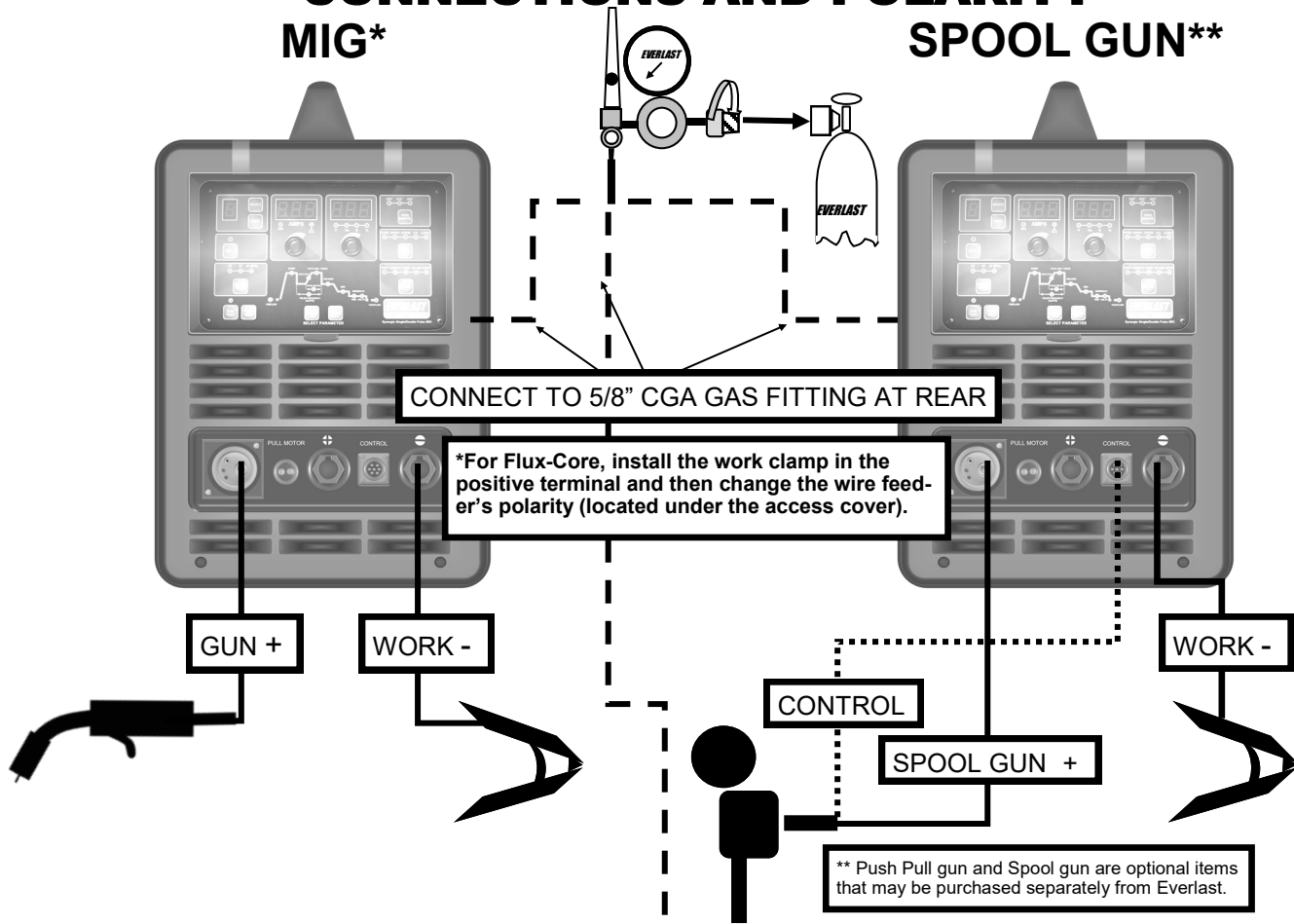

PUSH-PULL GUN**

STICK

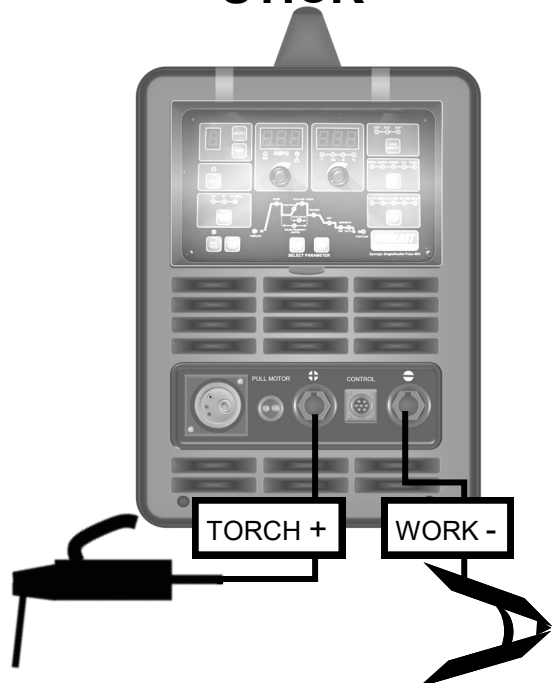
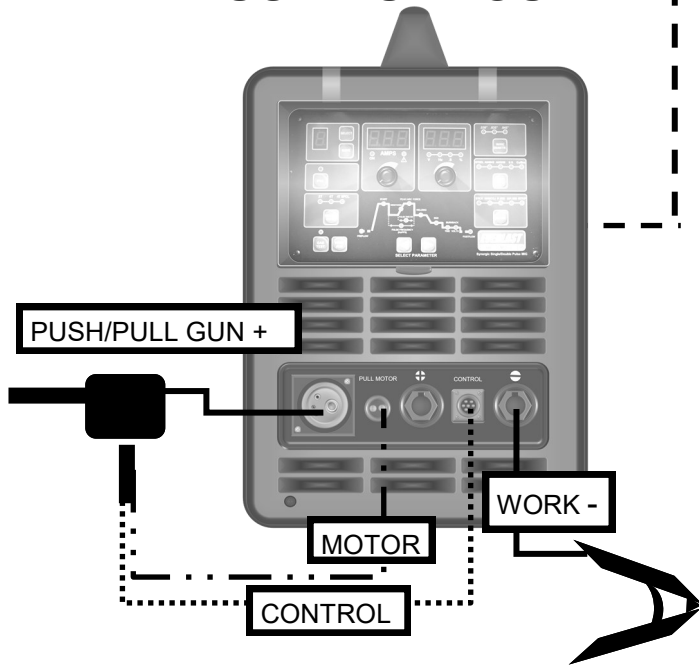

SECTION 2**SETUP GUIDE AND COMPONENT IDENTIFICATION****GENERAL POLARITY RECOMMENDATIONS***

Table 1 *Consult the manufacturer of the filler material recommendations concerning polarity .

PROCESS	TORCH POLARITY	WORK POLARITY
MIG (GMAW)	+	-
FLUX CORE (FCAW)	-	+
STICK (SMAW)	+	-

Table 2 **GAS SELECTION GUIDE**

PROCESS	GAS
MIG (GMAW) STEEL	For best operation in Synergic Pulse Spray: 90/10 (optimum), 95/5 (maximum), 82/18, or 80/20 (minimum) Ar/CO2 For best operation Short Circuit MIG: 75/25 Ar/CO2 or 100% CO2
MIG (GMAW) STAINLESS STEEL (INOX)	For Synergic Pulse Spray: 98/2 Ar/O2, 98/2 Ar/CO2 For Short Circuit: Tri-Mix or 98/2 Ar/CO2
MIG (GMAW) ALUMINUM	For Synergic Pulse Spray: 100% Ar For Standard Spray: 100% Ar

Table 3 **DC STICK (SMAW) OPERATION GUIDE**

METAL THICKNESS	ELECTRODE SIZE	WELDING AMPS
< 1 mm/.040"	1.5 mm/ 1/16"	20-40
2 mm/.080"	2 mm/3/32"	40-90
3 mm/ 1/8"	3.2 mm/1/8"	90-110
4-5 mm/ 3/16"	3.2-4 mm/ 1/8"-3/16"	90-130
6-12 mm/ 1/4"-1/2"	4-5 mm/ 3/16"	130-200

INSTALLING THE WIRE SPOOL

To load the spool of wire:

1. Loosen and remove the hand nut on the spool carrier by turning it counter-clockwise.
2. Align the locating pin with the hole on the wire spool (if present).
3. Slide spool onto the shaft. Make sure wire is unwinding from the bottom of the spool.
4. Adjust de-spooling tension by turning tensioner located under the hand nut on the spool carrier.
5. Lightly spin the spool. If it free-wheels more than 1/4 turn, tighten hex screw a little at a time until it doesn't. If it does not free-wheel at all, loosen tensioner until it free wheels 1/4 turn.
6. Reinstall the hand nut so the spool is retained securely.
7. Locate the end of the wire and clip the bent end of the wire so that it will feed through the wire feed mechanism smoothly. Carefully hold the spool of wire with one hand so the wire will not de-spool. Proceed to instructions listed below: "To thread wire from the spool properly through the wire feeder into the gun."

NOTE: An adapter/spacer will be needed to use 8" spools. Contact Everlast to purchase one if you do not have an adapter.

NOTE: Be sure to use special serrated drive rollers while using Flux-Cored wire and dual shielded wires. The serrated rollers are available as an option. Contact Everlast to purchase Flux-core drive rolls. Also, don't forget to change gun polarity to (-) for flux core use..

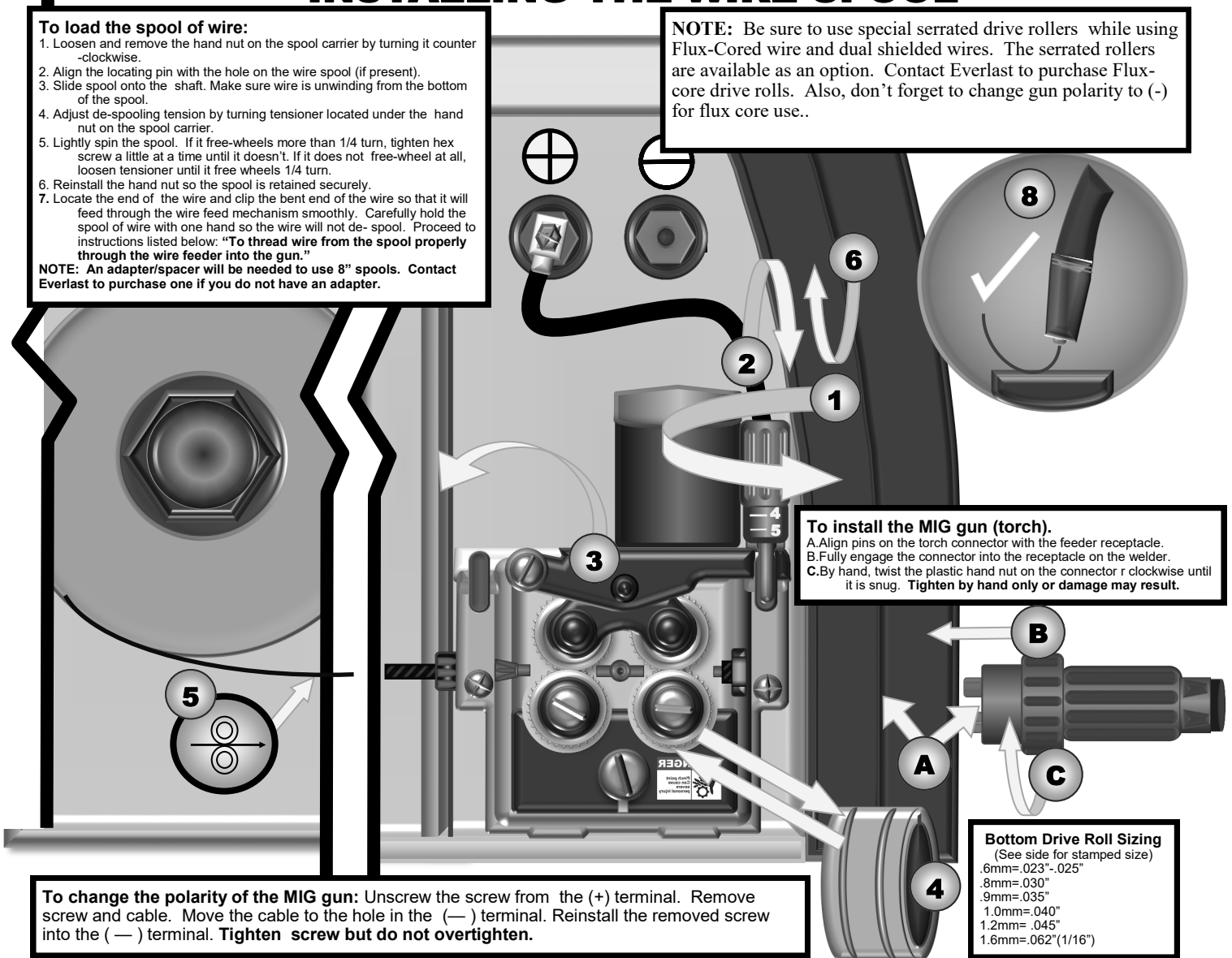

To install the MIG gun (torch).

- A. Align pins on the torch connector with the feeder receptacle.
- B. Fully engage the connector into the receptacle on the welder.
- C. By hand, twist the plastic hand nut on the connector clockwise until it is snug. **Tighten by hand only or damage may result.**

To change the polarity of the MIG gun: Unscrew the screw from the (+) terminal. Remove screw and cable. Move the cable to the hole in the (-) terminal. Reinstall the removed screw into the (-) terminal. **Tighten screw but do not overtighten.**

Bottom Drive Roll Sizing

(See side for stamped size)

6mm= .023"-.025"
.8mm= .030"
.9mm= .035"
1.0mm= .040"
1.2mm= .045"
1.6mm= .062"(1/16")

To thread the wire from the spool properly through the wire feeder into the gun:

1. Install the MIG gun as instructed in "To install the MIG gun (torch)" above. Loosen the top idler roller tensioner, rotating the black tensioner knob counter-clockwise.
2. Flip the tensioner down, toward you, releasing the carrier arm that holds the top drive rolls.
3. Raise the carrier arm up. Inspect the drive rolls to make sure that each roller's groove size matches the wire diameter. Also make sure correct type of drive rollers are used. i.e. Flux-Core drive rolls use special serrated rolls. (Top driven rollers do not have grooves and are not to be removed).
4. Reversal of the lower drive rollers to select the right size drive groove may be necessary. **To reverse the lower drive rolls:** Remove the slotted screws securing each lower drive roll. Pull each retaining spacer. Remove the outer ring of the drive roll and flip the drive roll over. The drive roll is actually made of two pieces. Hold the inner assembly of the drive roll on with one finger (to prevent it from slipping off the shaft), while slipping the outer "rim" of the drive roll off with the other hand. **NOTE: Both inner and outer parts of the assembly have locating keys.** To reinstall: Line up the outer rim of the driver rolls keyway with the locating key. Reassemble and tighten each roller. Make sure both rollers are matched in size. Also make sure the locating keys are in place and have not pushed or slipped out of their grooves during assembly. Lightly coat the inner mating surfaces with light lube if necessary to prevent future seizure. Do not lubricate the surfaces of the drive rolls or wire slipping and erratic feeding may result.
5. **Follow instructions above: "To Load Spool of Wire."** Make sure the spool of wire is loaded correctly so that the wire unrolls from the bottom of the spool (counter-clockwise). Thread the wire into the coiled guide and over the grooves in lower drive rolls. Thread the wire fully through until it threads into the gun section 4"-6". Lower the upper drive rolls into contact with the lower drive rolls, keeping the wire securely fixed in the grooves of the lower feed rollers. If needed, use a screwdriver with a fine blade or small pick to keep wire from moving out of the grooves until step 6 is completed. Make sure one last time that the correct groove has been selected.
6. Raise drive roll tensioner back into place. Tighten it slightly so the wire will feed. Notice markings on tensioner for future reference.
7. **Remove the contact tip from the torch. (Not Shown).** Hold the torch cable and gun as straight as possible, in direct line with the unit so feeding of the wire through the gun liner is smooth and easy.. Press the gun trigger to feed wire until the wire exits the end of the torch. Reinstall the contact tip over the wire over the wire and tighten it.
8. To prevent bird nesting or slipping of the wire, adjust the tensioner clockwise until the drive rolls will not slip when the wire comes into contact with a hard surface. The wire will curl up on end while feeding under power. If you over-tension the wire, you will increase the chances of bird nesting of the wire (balling up of the wire or curling of the wire around the drive rolls), so it is best to tighten just until wire stops slipping and is able to curl up. Extra tension can deform wire and prematurely wear the drive rolls. Slowing of the feeder may result as well. **Remember not to test on any metal attached to the work clamp to prevent the wire from arcing while performing this test.**

FRONT VIEW/ MAIN PANEL POWER i-MIG 253DPI



Front Panel Description and Explanation:

1. **Protective Cover.** The unit features a protective hinged cover. This cover should be lowered whenever welding is actively taking place or when the welder is stored for an extended period of time.
2. **Volts/Function Display and LEDs.** The Volt/Function display works in conjunction with the LEDs directly below the display to indicate the values of specific functions. As the "Select Parameter" button (#10) is pressed, the LEDs will light up, one at a time while progressing through the parameter menu (graph). The LED indicates which function value is currently being shown in the display. The list of functions controlled in this display are: Volts (V), Hertz (Hz), Seconds in tenths/thousandths (.S), and Percentage (%). Each one of these represents a value of a parameter listed in the graphical parameter representation of the welding functions below in #6.
NOTE: Depending upon which mode is selected, not all LED's will be highlighted as you scroll through the parameters. The default function represented in the display is Volts. After adjusting or selecting each function, the unit will return to the Volt setting automatically within 3 seconds. While welding, this display changes from set voltage to dynamically display actual welding voltage output while welding.
3. **Amps Display and Warning LEDs.** The Amps display is a single purpose display and is used only to display selected Amps or dynamic Amp output, depending on whether or not the unit is actually welding. The actual Amp output will vary somewhat in standard modes and will actually display a different Amp output in pulse mode since the unit figures an "average value" of the pulse Amps. During Amp selection, in Pulse mode, you are only selecting for the "Welding Amps" and not the Pulse values. The synergic function of the Pulse mode takes over and figures the balance of the pulse settings which will create a displayed Amp output while welding that is slightly different than set. However, this should not be of concern, other than a reference of overall heat going into the weld.
Keep in mind that when you are adjusting Amp output, you are also adjusting wire speed. While wire speed is commonly used as a reference in lower tier MIG welders, it is not the most accurate way of adjustment and measurement. Wire speed only gives you a reference of

Inches of wire delivered to the weld in one minute. However, if you are to swap the wire spool and change wire diameter, the same wire feed setting used with the first roll will not produce the same amp output in the second roll because the wire diameters are different. With lower tier welders, you often don't have an option to program the wire diameter into the machine, so wire speed is the only figure that can be used as a referenced value until the unit starts welding and a built-in sensor can measure and display the actual Amps being delivered to the weld. With this unit, even in standard mode, you are able to input the wire diameter, from .030" to .045". This ensures the most precise method of regulating the weld parameters. **As a reminder: Always remember to select the wire diameter first so that the amps can be correctly displayed during adjustment.** With wires larger or smaller than the listed wire diameter calibrations included in #5, select the nearest diameter to the size that is installed. While this won't be 100% accurate, it can be used as a relative reference for setup. In this case, you may have to rely on sight and sound to accurately set up the welder, as you would with a MIG without a display. See conversion factors found later in this manual for figuring approximate wire speed and amperage. The **LED ON Indicator** directly underneath the display should be lit anytime the machine is turned on and the unit is receiving power. If the unit is switched on but no ON light appears and the fans do not start, check for a tripped breaker and check for incoming power at the receptacle. You may notice that the ON indicator along with the displays and fan, may remain powered up to 10 seconds after the unit is switched off as the capacitors discharge. This is part of normal operation  and not a defect. When the **LED Warning Indicator** lights up, the machine power output will cease. This is due to the fact that the duty cycle has been exceeded and the unit has over-heated. If this occurs, allow the machine to run so it can continue to cool the electronics for 15 minutes. If the machine does not automatically reset after this time, switch the unit off and turn it back on. If the machine does not reset, check the fuse. If the fuse is good, call Everlast tech support for further diagnosis procedures.

4. **Synergic Function.** The Synergic function is used to simplify setup and improve results while welding. It eliminates the need for the operator to

know complex algorithms or to have extensive experience at setting up complex parameters related to MIG welding, especially Pulse parameters. The Synergic function of the Power i-MIG 253DPi applies to non-pulse, single pulse and double pulse forms of MIG welding. In standard non-pulse MIG mode, the synergic function is optional and can be turned on and off. However, in all pulse MIG modes, the synergic light will stay illuminated as a reminder of function and cannot be deselected (turned-off). To select for Synergic operation simply press the button to illuminate the LED located directly over the button. Then, select the relevant parameters in items #5 and #6 (see reference picture on previous page for comparison). **Note: The synergic non-pulse MIG mode is designed and intended for steel operation with Ar/CO₂ or 100% CO₂ shielding gas.** The operation, theory and differences in Synergic non-pulse MIG mode, Synergic Single Pulse MIG mode and Synergic Double Pulse MIG modes are discussed in more detail later in this manual. Please see the separate sections dealing with Basic MIG welding and Pulse MIG welding for more information.

5. **Wire Diameter Selector.** The wire selection parameter is used to ensure accurate Amperage calculation. The selection of wire diameter will be required in all modes including during non-synergic operation. If the wire diameter selected does not match the wire being used, the display will not accurately reflect the Amps until welding has started. If the size of wire you have installed (i.e. .023" diameter) does not have a counterpart in item #5, use the setting that is the next closest in size. However keep in mind that the Amp setting is only going to be able to be used as an approximation and is good for a reference setting only. This statement also applies to Flux-Core and dual-shield operation. In these cases, set the unit up using basic setup techniques used to set up MIG welders without a display. Also, it is suggested that in these cases that Synergic Mode not be used since it may require extensive altering of background settings to function correctly. Standard Mode will also allow the Voltage to be manually adjusted to the correct setting in these exceptions to wire diameters/types.
6. **Filler Metal Type Selector.** This function is designed to be used exclusively in Synergic Pulse Modes only. The input of filler metal type will always be required in both types of Pulse Mode.

In the non-pulse synergic mode, the unit defaults to Steel operation and does not allow selection for other Filler metal types since it is assumed that Aluminum, Stainless Steel (INOX), and Bronze will be used exclusively in the Pulse modes. In this case no LED will be illuminated.

Not every possible filler metal category will be listed on the panel. If the Alloy you are using is not listed, use the filler metal option that is most closely related to the filler metal type you plan to use. Any difference in settings can be fine tuned by the Voltage/Arc Trim feature, or by the Inductance if needed. Additionally there are background settings that can be altered to help correct any issues that cannot be corrected by tuning factory settings (though it is not normally needed). In the case of the Aluminum Alloy that is currently required by some manufacturers in auto body repairs, 5554, select the 5356 Alloy option. As a rule of thumb, always remember that with any 4XXX filler use the 4043 Alloy option. With any 5XXX filler use the 5356 Alloy option. The welding requirements are similar between them and the voltage offset/arc trim feature can quite easily dial the welder in if needed. These newer alloys have been field tested and proven to and work with the Power i-MIG 253DPi. This includes certification testing. The inductance feature can be further tuned for out-of-position applications if needed.

7. **Welding Mode Selector.** The welding mode selector button is used to select the desired welding mode. The modes that are selectable are Stick, Standard/Synergic MIG Steel mode (MIG/CO₂), Single Pulse, and Double Pulse modes. As the button is pressed each time, the LEDs will cycle and illuminate one-at-a-time, from left to right. **The Single Pulse mode and the Double Pulse mode can only be operated in the synergic modes. The synergic light cannot be deactivated when one of these modes is selected.** You'll notice that the "Setup" light is present in the series of LEDs as well, but is skipped over while cycling through. This is normal. This LED represents the hidden or background programmable part of the units welder. How to access this function and the adjustable background parameters that are controlled by this function will be covered in greater detail separately in the appendix of this manual. The Setup should not be accessed unless the operator is sure that changes are needed as it will significantly alter the factory programmed settings. The Setup function has a hidden feature that also allows the original

factory programming to be reloaded. **Do not access this function casually! Be aware that accessing this function without the proper knowledge and understanding of the adjustment will have potential negative effects on weld quality and performance.**

8. **Volt/Function Selector.** This control simply is used to adjust the parameter value that has been illuminated directly under the digital display. The default adjustment value will always Volts. The LED will always be illuminated unless adjustments are being made to one of the other parameters. When the select parameter button (item #10) is used, the value associated with the selected parameter will illuminate in the graph (item #11) and will be displayed temporarily in the display for up to 3 seconds. As long as the knob is being adjusted, the selected parameter value will remain in the display until adjustment is completed. 3 seconds after the unit senses no adjustment is being made to the selected parameter, the display will revert back to reading voltage and the “V” light will be illuminated. If this happens and you are not finished adjusting the parameter, you will need to reselect and highlight the LED associated with the desired parameter located in the graph and begin adjusting within 3 seconds. **Additional values other than Voltage (V) are as follows: Hertz(Hz).** Hertz represents the number of times per second the pulse cycles. Also referred to as Frequency, the Hertz function will only be adjustable in Synergic Double Pulse mode. **Seconds (.S).** Seconds adjusts the amount of Time in thousands or tenths of a second a part of the weld cycle remains active. A period in front or middle of the number is the decimal point. Burn-Back Time, Pre-Flow and Post Flow Times are represented in Seconds and will always be accessible in all MIG modes. **Percent.** Parameters that aren’t expressed in time, frequency, or seconds are represented as a percentage of total adjustable value. In the case of the Power i-MIG 253DPi, Pulse Time-On is the only parameter related to this value and is only accessible in Synergic Double Pulse mode. **Inductance.** Though not represented by an individual LED under the Volt display, the inductance is a dynamic form of control over the welding arc. This means that the arc quality, or feel can be changed to suit the needs of the operator and welding position. When Inductance is being adjusted, no LED under the Volt display

will be highlighted. It is only represented by a “relative” range of inductance control and not a quantified amount. This function is discussed more later in the manual. **Important Note:** In Synergic Non-Pulse and Synergic Pulse modes, Volts will not actually be displayed as a standard Voltage value, even though the “V” is highlighted. An adjustable range of -5 to +5 will be displayed as the represented value. This is still a form of control over voltage, but when in a synergic setting, it is used to actually “offset” the factory programmed voltage value. Some companies represent this as an “arc length” adjustment, or more commonly, “trim”. While this is really an issue with semantics, the synergic mode actually keeps you from being able to adjust the full voltage range in order to prevent you from getting the welder too far off of workable parameters. The values of -5 to +5 are adjustable in tenths. The values do not represent whole volt changes, but rather a value that is only relative to the factory programmed voltage. It is also worth mentioning that the factory setting is often slightly high when using commonly available mixes of gas in the US. This does not mean the setting is not accurate. It does mean that the unit can accommodate different gas mixes, especially customized blends for special applications. This is intentional. Different gases will result in different offsets. Keep in mind that Volts in MIG welding are used to control arc length. So, if you turn down the voltage offset, you will decrease arc length. As a “best” practice, consider always starting lower in the adjustment range. Then, raise the Volt offset value in half number (.5) increments. Once close to a desirable value, fine tune in one tenth increments at a time (.1) until best results are achieved.

9. **Amp Selector.** The amp selector serves only one basic function. That function is to adjust amps. If you are looking for a wire speed adjustment on this welder, this is it. Amps and wire speed are not separate functions. In the simplest and most practical terms, these are actually the same function, but a different way of quantifying and displaying it. Wire feed speed adjusts amp output of the welder. However, due to the nature of synergic welding and the accuracy of adjustment that Amps provides over wire speed, this welder uses Amps. Most welding standards and protocols call for values in Amps. If you need a wire speed conversion, we have provided a basic formula for you and is found later in this manual in the broader discussion of MIG welding.

- 10. Parameter Selector Buttons.** The left and right arrow buttons adjust parameters located in the graph (item 11) located directly above the button. Each press of the button results in a newly illuminated LED which follows the progress of the weld function as it travels through the adjustable parameters. Note that all parameters will not be adjustable as the buttons are pressed. Some parameters will be blocked and the associated LED will be skipped over, depending upon the welding mode and trigger function selected. This is not a defect, but a part of the normal function of the welder. **If the Parameter Selector Button is not used for a period of 3 seconds, the reading will default back to the Welding Voltage.**
- 11. Weld Cycle Graph.** This graph contains the basic parameters related to setup and adjustment of the welder during the weld cycle. The graphical representation follows the cycle from beginning to end. It also includes the adjustable parameters of the Single Pulse and Double Pulse functions. The “Welding” LED is the default LED that will always be lit unless the “Select Parameter” button is being used to cycle through the graph parameters. When the LED is located in the default position, the Amps and the Volts/Volts Offset are adjustable. For a full list and discussion of each feature in the graph, see the end of the “front panel” section where each function will be individually discussed.
- 12. Program Selector and Save Function.** A combined total of 10 different programs may be saved, whether it is in MIG or Stick modes. Ten programs is sufficient to allow the most frequently used settings to be stored and instantly recalled by using the green selector button to toggle to the stored program number. Keep in mind that the unit is not designed to save 10 programs in each process, but only a total of nine programs. To save a program, toggle with the green “select” button to the desired number where you wish to save the program. During toggling, the Program number LED will light up. Make sure this is an unsaved program number or one that you are willing to have erased as the programming does not block you from saving over an old program. Make sure all desired settings are correct before you save. Then press and release the green “Save” button. **The display will flash to confirm that the programming has been saved.** Be sure to write down which program number you have saved and the basic settings you wish to preserve in case you accidentally resave over an old program.
- 13. 2T/4T/4T Special Function Selector.** The purpose of the 2T/4T/4T Special function selector is to two fold. First, the function selects the desired operation of the MIG gun trigger. 2T offers conventional “press and hold” operation of the torch trigger. 4T offers a 4 movement operation of the torch switch. In this arrangement, the torch trigger is pressed to start the arc and released to weld. When the weld nears termination, the torch trigger is pressed again and released complete and terminate the weld. 4T Special mode operates similarly. The second purpose of the function, is to offer increasing access to functions located within the welding graph. 2T offers minimal access and adjustment opportunity to the weld graph features. This reduces the need for operator input, but also allows the least customization. 4T offers more access, and 4T offers the most access and control over the weld cycle by offering full access to all the functions that are relevant in the selected welding mode. **Note: All functions may not appear to be available in 4T special mode due to the welding mode selected. Only certain functions apply to each welding mode. See the chart on 2T/4T/4T Special functions following in the appendix section for a full listing of functions available.**
- 14. Gas Flow Test Selector.** This feature is used to allow the operator to set and test the shielding gas flow rate. To operate, press the button and hold it until the gas flows and adjustment or testing is finished. Release the button to terminate the gas flow. This function is not designed to lock on, in case it is forgotten and left locked on. This prevents accidental draining of shielding gas cylinder contents in the process and possible asphyxiation.
- 15. Wire Jog Selector.** The wire jog is used to help the operator safely install the MIG wire and feed through the cable and gun without wasting gas or energizing the wire feed. This function operates independently of the gun trigger. **Do not try to operate the wire jog while in stick mode. The wire will be live if fed out and may cause accidental arc striking.**
- 16. Euro Quick Connect for MIG Gun.** This style of connection makes the Power i-MIG compatible with many after market MIG torches/guns.

Connect the MIG torch by aligning pins on the gun cable with the receptacle and pushing in. Twist the collar on the cable connector to lock in place. Do not use pliers or other tools to tighten. Hand tighten only. This type of gun connection is typically superior to many others because it is self contained, does not require tools to connect and does not have a separate control connector that also needs to be plugged. This connector has a reliable and proven track record with many companies throughout the world. **Note: When using the spool gun or the push-pull gun with this welder, this port also becomes the attachment point for the spool gun, so the main gun will need to be removed. This connection becomes live (hot) when the stick mode is activated. You may leave the gun connected during stick welding. However, the wire and nozzle should be protected from accidentally touching the work or welder during use. A short piece of rubber hose can be used to slide over the nozzle to protect against accidental touching of the wire to the work piece or welder. A “best” practice is to remove the gun when welding in stick mode.**

17. **Pull Motor Connector.** The push-pull power lead connects to this 2 pin connector on the Push/Pull gun. This powers the gun.
18. **Positive Polarity Connector (+).** This front mounted connector terminal is a standard 35 series DINSE style connector. It provides a positive polarity output. When using stick mode, connect the cable from the electrode holder to this terminal for most electrodes and applications. When using Flux-core or dual shield, connect the work clamp to this port, unless the wire manufacturer specifically states an electrode positive polarity (also referred to as Reverse Polarity).
19. **Control.** This seven pin plug is used to control wire speed when the spool gun or push-pull gun when it is connected.
20. **Negative Polarity Connector (-).** This front mounted connector terminal is a standard 35 series DINSE style connector. It provides negative polarity output. When using stick mode, connect the cable from the work clamp to this terminal for most applications. When using Flux-core or dual shield, change polarity inside the machine by changing the buss-bar position, unless the wire manufacturer states to use electrode positive. Do not use this connection for most Flux-core and Dual shield wires that require Elec-

trode negative polarity (Straight Polarity). Connect to the work clamp while in MIG/Stick mode.

Features found in Weld Cycle Graph (item #11) from left to right.

1. **Pre-Flow Timer.** To improve weld quality before the weld begins and to reduce porosity, shielding gas Pre-Flow has been provided. This is especially important in Pulse-MIG welding. Pre-Flow is the length of time that shielding gas flows before arc initiation after the gun trigger is pressed. The Pre-Flow provides a blanket of shielding gas to surround and enclose the weld area so that the wire does not have a lesser chance of oxidizing and creating porosity due to the presence of oxygen in the weld at the time of arc initiation.
2. **Hot Start.** Hot Start creates an initial higher “surge” of volts and amps at the beginning of a weld. This is designed to help reduce porosity and lack of fusion at the start. In special circumstances, it also can be used to set a lower, cooler start if needed to prevent burn-through. Aluminum is especially prone to lack of fusion at the start of the weld. **The Hot Start feature is only available in Single Pulse MIG or Double Pulse MIG modes and can only be selected and adjusted in the 4T Special mode. Any other combination will deny access to this feature. Changing to 2T or 4T will cause the unit to deny the use of Hot Start even if originally set in 4T Special mode and is in a Pulse MIG mode.**
3. **Inductance.** Inductance varies the current rise time during MIG welding. This affects the actual point where the current potential has risen sufficiently to burn back the wire after pinching off and depositing in the puddle. The point at which it has burned back is considered the “pinch point.” This is where the wire will begin to once again melt and transfer. To put it in more practical terms, the user will see that the wire is sticking out longer or shorter from the MIG torch before it burns away, depending upon the exact setting. This controls spatter, penetration and bead profile. When the arc force knob is rotated from one extreme to the other, the operator will observe that the arc is more stiff with a shorter arc length toward the high end (towards 10) or more fluid at the low end (towards 1). Bead profile changes will occur as well. A stiffer arc will produce a deeper but more narrow profile. A fluid arc will produce a wider, shallower weld, usually with an improved bead appearance and less spatter. If long arc length, especially while welding Aluminum, is encountered and becomes a problem, increase arc length towards the

high end. Arc force control is also known as inductance control, slope or wave form control (MIG). By changing the level of inductance, the user can fine tune the arc performance so the welder responds in a manner that the user is accustomed to with other brands of machines. The arc sound will also change as the arc force is adjusted, going from a relatively high pitched whine to a frying sizzle. The value of this function cannot be overstated for controlling the arc characteristics of the weld, especially in Pulse MIG mode. **The key to using this feature successfully and getting the most out of it is to set this after Amps and Volts/Off-set (Trim) functions have been adjusted and tested. This feature is also used to fine-tune results when custom blends or non-standard gas mixes are used.**

4. Peak Double-Pulse MIG Value/Stick Arc Force Control. This LED represents an entirely different function for the Synergic Double-Pulse MIG and Stick welding modes. ***For operation in Double-Pulse (often referred to as Pulse-on-Pulse) MIG mode:*** This feature is actually available for selection in Double-Pulse Mode. The Double-Pulse mode is composed of two “layers” of Single-Pulse and divides it up into half-stages: High and Low. In each stage, the Amps and Voltage Offset (Trim) can be adjusted just as in single pulse. The “Peak” or rather “High Stage” value of the Pulse is represented by this LED. All adjustments are made as in Single Pulse mode. However, it should be kept in mind that this part of the Double Pulse is the “Hot” stage that provides the Penetration and more rapid melting of the base metal. This portion of the pulse should be set with higher settings than the base part (represented by the Welding LED) of the Pulse or results will not be satisfactory. ***This LED is not accessible in Single Pulse Mode.*** For more information, see the Pulse MIG section. ***For operation in Stick mode:*** The LED in the stick mode represents the Stick Arc Force. It is used to automatically vary the automatic arc response while welding. While stick welding, the arc force counter acts the drop in voltage experienced when the arc length is too short and falls below 20 volts. The amps are automatically increased to offset the loss of voltage to maintain the welding arc and prevent the rod from going out and sticking. It can also be used to help increase penetration by the operator “pushing into the puddle” when more heat is needed. The arc force amperage “boost” is represented as a percent over set amperage that the amperage can be increased. Too much arc force while stick welding can cause burn through an violent

splatter. A low setting of 2 to 3 can be helpful with rods such as E7018, 7014, and 6013. E6011 benefits from a higher setting.

5. Pulse Time-On. The Pulse Time-On function represented by this LED, is used to control the balance of the “Peak” (#4) to “Base” (#) time of the Double-Pulse. The Double-Pulse is separated into two layers of Single-Pulse action. The Pulse Time-On adjustment is used to skew the amount of time that each Single-Pulse layer stays “on” during a single, complete cycle of the Double-Pulse. Obviously, this can be a little confusing to novice users. In an effort to understand this function, imagine that a “balanced” setting between the 2 stages (high and low stages) represents a 50/50 setting. This means the stages are equal to each other in time length. Each stage stays “on” for the exact same amount of time as the other stage during one full cycle of the Double-Pulse. In other words, the two stages when added together, form one complete cycle of the Double-Pulse, when put together. The Peak stage of the Double-Pulse will remain on as long as the Base stage of the Double-Pulse at this setting. However, on this welder, instead of representing the value of the Pulse Time-On as 50/50, the pulse value is actually represented on the machine at 50%. Now, the 50% value represents how long the “Peak” Pulse stage stays on in relation to the “Base” Pulse stage. This means that a setting of 25% would mean that the “Peak” Pulse stage would stay on 25% of the time during one Double-Pulse cycle. This would also mean that the “Base” stage of the Pulse would take up the remaining 75% of time left in one cycle of the Pulse. The range of value is 10 to 90%. Starting at 90%, and adjusting downward will increase the separation of the puddle and allow greater freezing action to occur. Also, note that the lower that you set the Pulse time-on the greater separation you will get in the finished puddle, and the greater control you will have. However, as you gradually lower the Pulse Time-On settings, forward travel speed during the weld will be reduced slightly as time the “Hot” stage is reduced and more “cooling” stage is introduced. **When setting up the unit, the best results will often be obtained from 25 to 75% Pulse Time-On. Though this is not absolute, 50% is a good starting point.**

6. Pulse Frequency. In order to form the Double-Pulse, the Pulse cycles between two layers of Single-Pulse. The number of times per second that the Double-Pulse fully cycles between the two layers of Single-Pulse is called **Frequency**. Frequency is commonly referred to as Pulses per Second (PPS). On the Power i-MIG

253DPI, this value is represented by “Hertz” or “Hz”. Hertz is the international standard used to represent any type of basic frequency. One Hertz equals one full Pulse cycle per second, or more simply, one pulse per second. This unit is designed to cycle between .1 and 9.9 Hz in Double Pulse Mode. Keep in mind, that this is how fast the Double Pulse cycles, not how fast the single pulse cycles. The Pulse Frequency (Hz) of the Single-Pulse is set by factory programming (synergically) and is based off user input of wire diameter, filler type and metal thickness (Amps). Assuming the same travel speed, lowering the Pulse rate (Hz) results in greater definition and distance between the weld ripples. Increasing the Pulse rate results in tighter stacking of the ripples. Increasing the Pulse rate does have the advantage of constricting the arc, and reducing the width of the bead but may result in less desirable appearance. When setting up the Double-Pulse for the first time, start with 1 to 3 pulses per second to offer the best balance of ripple spacing and puddle control until technique and experience is developed.

7. Welding Mode Control. This LED represents the default setting of the welder. It represents similar but different values in each welding mode. **In Standard, Non-Pulse MIG mode:** This represents the mode in which you adjust Amps and Volts. **In Synergic, Non-Pulse MIG mode:** This represents the mode in which you adjust Amps and Voltage Offset (Trim). While adjusting the Voltage Offset, you will see the Offset displayed and then a briefly see the actual voltage that has been assigned to the setting. Offset Values will be between -5 to +5. **In Single-Pulse Mode:** This represents the mode in which you adjust Amps and Voltage Offset. (Trim). Voltage Offset values will be between -5 to +5. You will see no reflection of true voltage since Voltage is Pulsing rapidly between two factory preset levels and is irrelevant until the weld is started. **Double-Pulse Mode:** This represents the “Base” stage of the Double-Pulse welding mode. This is the low Pulse layer of the Double-Pulse mode. In comparison to the “Peak” Pulse value in item #4 on this page both Amps and Volts are pulsed synergically at a lower average value. This layer of the pulse is used as the cooling stage, or the freezing stage that allows the weld puddle to cool to the point that it creates the desired “ripple” in the weld. When used correctly, this creates the “Stack-of-Dimes” look that simulates TIG welding. **Keep in mind that this function should be set to a lower value than the “Peak” Double-Pulse value to achieve desirable results.**

Setting the “base” layer too high will result in little puddle cooling. This will manifest itself in too much puddle fluidity. For a beginning setting, try setting the Amps at a 50% value of the Peak. Keep the Voltage Offset at the same value as used in the “Peak” value. As skill develops, some variation of the Voltage offset may be experimented with, but as a general rule, changing the Voltage Offset in either the Peak or the Base layer will result in varying arc lengths which may destabilize the arc and increase spatter.

8. End/ Arc Termination Control. The End LED represents the final active welding setting of the weld. This end stage of the weld cycle is used to complete the weld in 4T mode and 4T special mode. This is used to fill the crater at the end of the weld using a lower setting that used for welding. By retriggering the torch trigger ad holding, the weld will begin to cool and the arc reduce. The wire feeding will terminate when the gun trigger is released. In this mode, be sure to set a lower Amp value than used for normal welding. Typically, there is no reason to alter Volt offset, but if problems are encountered with too short of an arc during this phase, set the Volt offset to a lower setting.

9. Burn-Back Timer Control. The burn-back timer controls the amount of time that the arc stays engaged *after* the trigger is released and the wire feeding stops. This is to help reduce wire stick out and reduce the need to trim the wire before starting another weld. Also, it helps to prevent craters in the weld by tapering off the heat during arc termination. A final benefit of burn-back control is that it prevents the wire from sticking in the weld puddle once the arc is stopped. **For best results this should be combined with the Post-flow setting in mind so wire does not become oxidized during the burn-back process. (As a “best practice” keep Post-Flow activated at least one second longer than burn back, more if welding thick metal at high amps.)** If too much burn-back time is used, the wire may burn back up into the tip and seize. Increase burn back by only increments of .05 to .06 of a second to prevent over adjusting the burn back and destroying the contact tip. Generally, burn-back control will produce consistent results and increase productivity. Different wire diameters and feed rates will change the burn-back time requirement. However, it is best to keep burn - back time, until personal experimentation yields better results, at a relatively low setting, less than .1 seconds. Minimum burn-back time is .01 Seconds. Keep in mind burn back control is another tool designed to help increase quality and repeatability of welds. Burn back control is available in all MIG welding Modes.

10. Burn-Back Volts/Volt Offset. This feature adjusts the Burn-Back Voltage or Voltage Offset/Trim. During Burn-Back, the Amps are not relevant since amps are a function of wire-speed and wire feeding is stopped during the Burn-Back process. Depending upon desired effect, and trimming requirements, the Burn-Back Volts/Volt Offset function should be set lower than or equal to the setting used for Welding. In standard non-Pulse MIG mode, the actual Voltage is reflected in the Volt display. In the synergic MIG modes, the display changes to read in values from -5 to +5, the same as the other synergic functions which feature Voltage Offset/Trim adjustment. Keep in mind that too high of a setting will create a rapid Burn-Back into the contact tip, which may necessitate the removal and premature replacement of the contact tip. Occasionally after a mild Burn-Back, the wire may break free and “jump” and feed out slightly after the tip cools. In this case, be sure to trim the tip before restarting to remove oxidation and impurities in the ball at the end of the wire.

11. Post-Flow. Post-Flow control improves weld quality by adding a brief period of shielding gas flow after the arc is terminated. The Post-Flow prevents oxygen getting to the weld and keeps oxidation from occurring as the weld cools. Post-Flow also improves Gun cooling. Pulse-Welding can incur more heat in a gun, so this is key to preventing premature Gun failure as well. During the cooling cycle and while the metal coalesces, both the wire and the puddle benefit from the Post-Flow process. As a “best practice”, always use a minimum of 1 second Post-Flow. For every 25 Amps over 50 Amps it’s recommended that you add at least 1 additional second of Post-Flow.

When the arc is terminated, you must continue to hold the MIG gun over the weld until the Post-Flow has been completed the set time and terminated for it to have the proper shielding and cooling effect. Removing or pulling the gun off prematurely can also interrupt the Burn-Back cycle as well.

SIDE VIEW POWER i-MIG 253DPI



Side Description and Explanation:

1. **Wire Spool Carrier Assembly.** Make note of the correct assembly order if disassembled. *The order in which they are assembled is important to be able to provide enough resistance to prevent de-spooling of the wire.* When inserting the spool, make sure the small tab or dowel on the inside of the spool holder is correctly located in one of the recesses made into the spool. After installing the spool of wire, tighten the hex head tensioning nut located under the spool retaining nut so that the wire will not continue to roll more than a 1/8th to 1/4th of a turn after the wire has stopped feeding. Do not tighten the tensioning nut to the point that the drive roller slips or the feeder motor strains while feeding the wire. The spool carrier assembly can accommodate rolls of wire 12" in diameter. The carrier can also support the use 8" rolls of wire with an optional adapter. If you do not have an adapter, contact Everlast to purchase one. **NOTE:** 4" rolls of wire are not supported.
2. **Polarity Connection.** Note the "+" and "-" symbols located on the inside of the unit next to the round brass terminals. One terminal will have a cable attached to it. The MIG unit is shipped with the torch polarity connected to the positive terminal. Positive polarity is designed to weld with solid wires. To weld with most Flux-core or dual shielded wires, the polarity must be changed to negative. To change the polarity to negative, simply remove the screw on the positive and move the cable over to the negative terminal. Reinstall the screw on the negative terminal. **Standard polarity for MIG is "+" (DCEP) with the work clamp in the negative.**
3. **Wire Feed Assembly.** Note the numbers on the side of the tensioner. These numbers are a reference point to help properly tension the wire so that the drive roller will not slip. Do not over-tension the wire because it can create a condition known as birds nesting, where the wire will tangle up around the feeder and will not slip if the wire burns back into tip, sticks fast in the weld puddle or other resistance is met. This will continue wrap the wire around the drive mechanism (bird's nesting) or will jam wire inside the gun liner until the trigger is released. Considerable effort is usually needed to clear out a bird's nest condition. Too little tension will result in wire slippage and cause rapid wear on the drive

components. Do a feed test before beginning a weld. Always make sure that correct wire size has been selected for both drive rolls. Make sure that the correct type has been selected to feed your wire. The size and type is stamped on the side of the drive roll. To identify type, note that a V marking denotes a V-Groove and is used for steel and stainless wires. A U marking is U-Groove and is used for Aluminum and Bronze. Occasional cleaning of the feeder mechanism is necessary to prevent wear and damage to the feeder and to the MIG gun liner. Regularly monitor any metal flaking and dirt build up that may occur in the wire feed area. Clean it away gently with compressed air. Also to improve MIG gun liner service life, blow out the gun liner with compressed air after running a complete full size roll through. Do not use harsh cleaners or solvents to maintain the cleanliness of the feeder mechanism. Felt wire lubricators may be bought and used to keep the wire feeding smooth and clean while using steel or stainless wire. **Do NOT over lubricate! Your unit has been supplied with additional drive roll sizes. Do not forget to change the contact tip size when changing to a another wire diameter. If a special Aluminum tip is not available for use, when welding with aluminum wires, use the next size up to prevent feeding problems.** Typically an aluminum tip is drilled oversize to prevent sticking as the aluminum heats up and expands. Depending upon the diameter and type of wire used, the MIG gun liner may need to be changed to work properly. The unit is supplied with an extra Polymer liner that should be used with Aluminum and Bronze wires. This allows the gun to be used while welding with these wires. If this isn't changed, then "bird's nesting" will occur. However, the 24 series gun with the stock length should be able to feed most Steel and Stainless Steel wire diameters without requiring a liner change. If trouble is experienced with feeding, purchase a liner specifically sized for your type and diameter wire.

REAR VIEW/BACK PANEL POWER i-MIG 253DPi

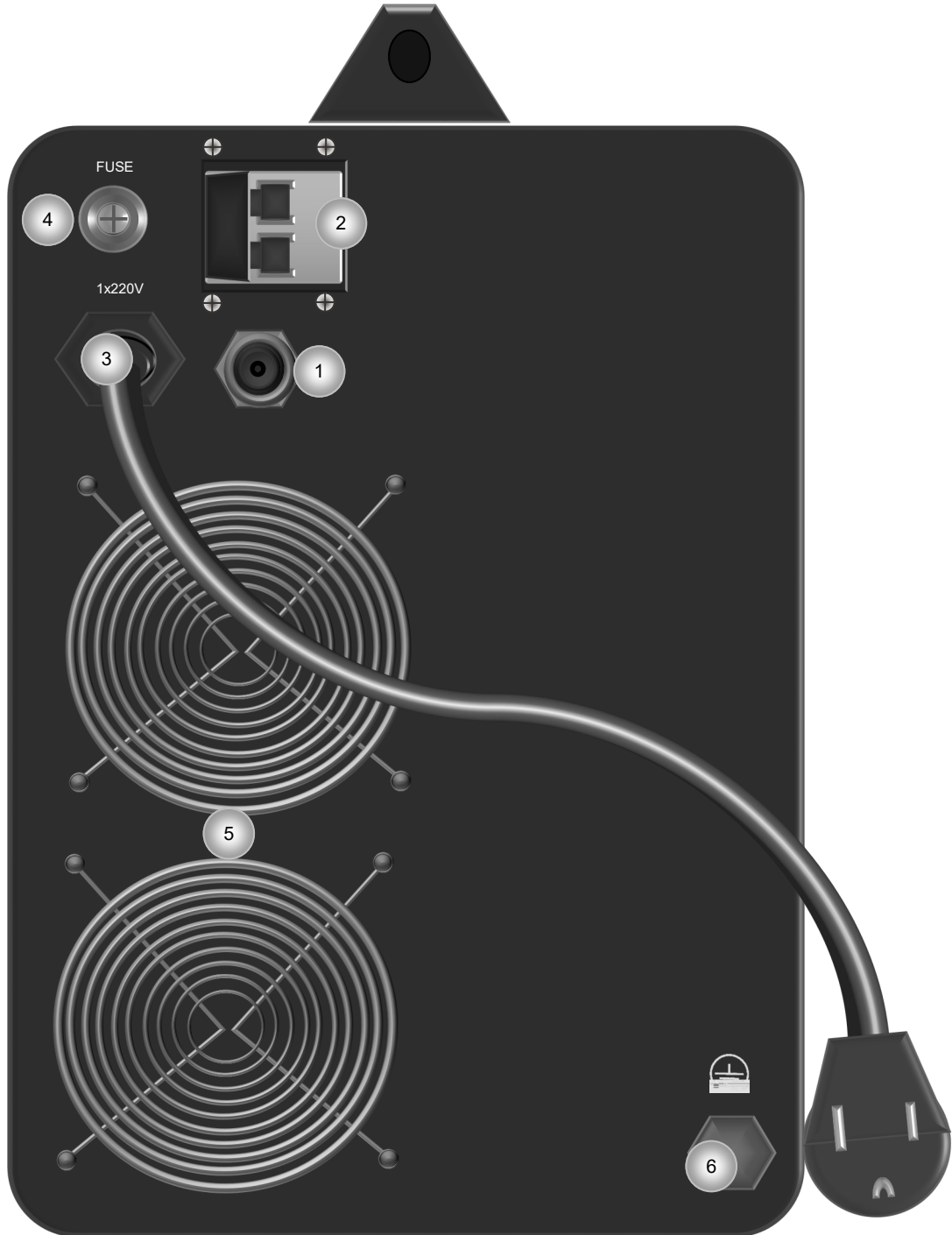

Rear Panel Description and Explanation:

1. **Gas Supply.** Connect the Gas regulator hose to this point via the brass barb fitting. (Regulator is customer supplied and not provided as standard equipment at time of publication.) The hose barb connection must be tight to prevent gas leakage. Install extra clamp if needed to prevent gas from escaping.
2. **Power Switch.** Turns unit on or off. This is a 2 pole single phase 240V breaker-type switch. If it is switched to the left, this means the unit is switched off. If it is switched to the right, and the unit is plugged into a good power supply, the unit should power up. **Note: When switched off, the unit will continue to run and appear to be switched on for up to 10 seconds as the capacitors discharge. This is normal.** However, if the unit will not switch off for some reason, the switch may be damaged. Turn off the unit at the main circuit breaker, and contact Everlast technical. Do not continue to use.
3. **Power Input Cable and NEMA 6-50P Plug.** The Power i-MIG 253DPi requires 220/240 V single phase 50/60 Hz power input. If necessary this unit will operate on 208V input as it is within the 10% voltage allowance. If actual voltage is below 205 volts, the unit may not function correctly. If used on a generator, the generator must be labeled as "clean power" and provide less than 5% THD. Consult your generator manufacturer for information regarding the clean power rating on specific units. Everlast does not provide a list of approved generators. Manufacturers rate their units as clean power independently according to industry standards. The plug is the NEMA 6-50P. This is the standard plug for welders operating on 240V in the US and Canada. Other countries will have different configurations.
4. **Fuse. 30A, slow blow.** This controls the main power to the panel and fans. If the unit suddenly stops, and no power to the panel is observed and the fans are not running, first check the main circuit breaker at the power panel and the power switch position on the back. Reset if necessary. If power isn't restored check this fuse. It's a standard automotive type 30A slow blow type available at many auto parts and electronic supply stores. Fuses can blow from overloading, circuit defect or simply from operation over time. support for information about replacement.
5. **Fans.** The unit is equipped with a dual fan system, which offers quieter and more efficient cooling. It must operate free of obstruction to preserve the high duty cycle which it offers. Keep all objects or restrictions at least 12" from all sides of the unit for proper cooling. If possible allow 18". Allow the unit to rest on the rubber pads/feet mounted on the welder. Do not have the bottom of the unit supported directly on the metal pan so air can circulate around the bottom as well. Do not run in an enclosed space such as a cabinet or work box. Do not grind or weld where sparks are directed toward the rear of the unit or metallic particles will build up on the fan blades and also on interior components. If metal builds up on the fan blades, it can cause them to vibrate and ultimately fail.
6. **Ground Bolt.** The unit is equipped with an additional grounding point for applications requiring a bonded ground. Under most conditions, the use of the ground is not required. Consult a local licensed electrician for installation and use of this connection.

BASIC MIG OPERATION

General Setup of Amps and Volts.

When you MIG weld with almost any basic MIG welder, there are generally two main adjustments that most users are familiar with: Voltage and Wire Feed Speed. (In this instance, the Power i-MIG 253DPi uses Amps instead of Wire Feed Speed and is discussed in more detail below. There are other brands that do this as well, but usually found in more advanced MIG welders) Both of these functions serve a purpose while welding and adjusting each affects distinct aspects of welder performance and finished weld quality.

The function of Voltage in MIG welding is to control the overall width and to a great extent, the height of the weld bead. In other words, voltage controls the bead profile. The Voltage adjustment also controls arc length to a great extent when set in a proper ratio to wire feed speed or Amps. Later, in the Pulse-MIG section you will see that Voltage is set differently during Synergic Pulse MIG than in basic MIG mode. However, for now, Volts remain fairly constant while welding. A MIG welder is often referred to as a “Constant Voltage (CV)” wire feeder.

If you are familiar with the Wire Feed Speed adjustment, then you may not initially understand where the Wire Speed Adjustment is on this machine. As a foundation to understanding MIG welding, you should keep in mind that the Wire Feed Speed function directly controls the Amp output of the machine, and the Amps, in turn, control penetration. With the Power i-MIG 253DPi, the unit actually displays in Amps, and not in Inches Per Minute. Initially, this may be hard to understand, but it is a more accurate way of calibrating your weld parameters. The fact that the Power i-MIG 253DPi displays amperage is not a disadvantage or an altogether different function from wire speed. To use a “non-technical” expression, Wire Speed and Amps are two sides of the same coin. You will be controlling the same function as wire feed speed, but expressing it in a different way. By using Amps as a reference for adjustment you have a more accurate way of expressing and controlling weld parameters. If you are used to using a wire feed setting to set up your MIG welder, you probably have observed that the wire speed that is needed to perform a weld is affected by wire diameter, all other things being

equal (Volts, metal thickness, type, etc.). A smaller wire will require a faster wire speed to produce the same Amps. A larger wire will require a lower wire speed to achieve the Amps as a smaller wire at a higher speed. This is because the diameter of wire controls or “restricts” the Amp delivering capability of the wire (Ampacity). The faster the wire is fed, the more amps it can deliver to the weld. By using Amps to directly represent this function, you end up with a more accurate way of determining the exact “heat” being put into the unit. Welding isn’t just about Amps or just about Volts. Rather it is about total Wattage being put into the weld ($V \times A = \text{Watts}$) Wire speed is meaningless unless the wire diameter is known. A procedure calling for a setting of XX.X Volts and 280 inches per minute will not be accurate if you run out of .035” wire during the middle of the project and have to finish with .045” wire at the same settings. You’ll have entirely different results. So, with this in mind, even in standard mode (non-synergic mode), the user must input the diameter of the wire being used so the projected Amp output on the welder can be accurately computed. Keep in mind that this is a projected output. There are a number of things that can affect the true Amp/Volt output of the welder in standard MIG mode, however it will be still be quite close to what is set. While actively welding, the display will change function and display actual amp and volt output. You may notice some small fluctuations with both Volt and Amp output while welding. This is normal and expected. In Synergic Pulse Modes this output reading of the displays may seem to be off from what is set by a more significant margin. This is normal. This is because while you are actively welding, the unit is “pulsing” Volts and even Amps (in double pulse) so Amps and Volts (Trim) will be computed as an averaged value since there is no way to reflect the change in pulse multiple times per second. If you are having difficulty understanding the relationship between wire diameter, wire speed and amps it can be easily figured with the following approximate industry conversions for non-pulse welding:

.023”: 3.5 x Amps = Inches per minute (IPM)
 .025”: 3.1 x Amps = Inches per minute (IPM)
 .030”: 2 x Amps = Inches per minute (IPM)
 .035”: 1.6 x Amps = Inches per minute (IPM)
 .045”: 1 x Amps = Inches per Minute (IPM)

BASIC MIG OPERATION

To convert welding requirements that may mention wire speed (IPM) into approximate Amps, or to find the Amp value equivalent of wire speed that you may be used to, use the following conversion formula:

.023": $IPM \div 3.5 = \text{Amps}$

.025": $IPM \div 3.1 = \text{Amps}$

.030": $IPM \div 2 = \text{Amps}$

.035": $IPM \div 1.6 = \text{Amps}$

.045": $IPM \div 1 = \text{Amps}$

Keep in mind these are approximate conversions and do fall off in accuracy as Amps are increased into the upper current limits for the given wire diameter.

Even though you will find general recommendations about setting the Amps, Volts and even shielding gas through a variety of free downloadable apps and online calculators, every filler metal manufacturer has its own specific parameters for Volt and Amp settings for each wire diameter and AWS alloy class of wire. **Note that wire speed isn't usually mentioned in wire manufacturer specifications, just volts and amps.** The range of Volt and Amp parameters generally varies somewhat from brand to brand, so be sure to read the packaging and/or manufacturer literature to determine what range of settings are recommended. The wire diameter also limits the practical maximum thickness of what can be reasonably welded. The issue with following charts, graphs and calculator recommendations is that most people find them either too hot or too cold. For some people, it may not even close. However, nothing can substitute for watching the arc and listening to the sound of the arc. In the short circuit transfer method of MIG welding, a crisp, steady sound, frequently referred to as a "Bacon frying sound" should be heard. The actual frying sound can vary somewhat and may have somewhat of a high pitch whine to it somewhere between the sound of a flying bee and a mosquito. If these sounds are present, look at the arc to see if it is steady, and producing low amounts of spatter. If large amounts of spatter are present, the puddle seems fluid (appears wet) and the wire speed is within the targeted range, decrease volts a little at a time to reduce the spatter. If this does not correct the problem, change the torch angle and

torch height. Hold the torch more vertical, with less than a 15 degree deviation from vertical and reduce stick-out of wire to 3/8" or less. If this still does not help, reduce the wire speed. Some spatter is normal, though it should be minimal overall.

The wire can also pop and spatter if the voltage is too low for the Amps (wire feed speed) and/or wire diameter. This is mostly observed as flying bits of red-hot but un-melted wire, along with popping as the wire inconsistently stubs into the puddle. This is followed by the wire pushing back against your hand pressure while the wire visibly turns white/red hot before burning off. Too low of voltage will also produce a high piled bead with the toes (edges) of the weld not properly wetting in resulting in poor fusion.

Inductance Control.

The third important variable in setting up the Power i-MIG 253DPi is the adjustable Inductance control. This setting isn't found on most basic welders. This isn't because basic welders don't have inductance, it's just because it is fixed by the welder's design. Regardless of whether it is fixed or adjustable, the amount of Inductance determines the feel of the arc at any given Volt and Amp setting. It is used to balance the stiffness of the arc against the wetness of the arc. It does so by adjusting the pinch point of the wire, and regulating how fast the droplets of molten metal are deposited in the weld. Some professionals refer to the "buttery-ness" of the arc. "Buttery-ness" is arguably somewhat a subjective term. However, it generally refers to how smooth and fluid the arc feels and looks. In fact, if adjustable, as is the case with this welder, the inductance alone can affect how much Amps or Voltage is needed in any given application. It does not typically require an altering of Volts or Wire Speed settings. However the Inductance control can expose poorly selected Volt/Wire Speed parameters by magnifying the effects.

While Everlast uses the term "inductance" on this model, it is known by many different terms. On some units it is referred to as "arc force". Often it is referred to as choke or slope and even dig. Simply put, the Inductance adjustment controls how long it takes the current to recover and rise to the established welding current to melt the wire after the

BASIC MIG OPERATION

wire contacts the puddle and the current falls. This process is happening many times a second so it isn't usually visible to the naked eye. But the overall effect is visible as the wire burn off height is changed and a change in the wetness of the puddle and how easily the molten metal flows in toward the toes of the weld as it melts off. If the unit has sufficient arc force, the edges of the weld will easily wick into the puddle with little or no spatter with little or no manipulation of the torch required. The pitch of the arc will be medium. With too much inductance the puddle may be uncontrollable, high spatter and the arc will have a throaty, raspy sound. Too little inductance and the puddle will be narrow and possibly have a high ridge in the center. The pitch will be very high and the puddle will seem sluggish and less fluid. The Inductance changes somewhat in Pulse MIG and increasing it shortens the arc length and increases the stick out of the wire. The frequency of droplet deposition is increased, accompanied by a higher pitch sound to the Pulse. With Aluminum, it is particularly important to run on the high side of the Inductance if the wire seems to melt too far back before pinching off and streaming into the puddle.

All MIGs have a built-in amount of inductance or arc force that is inherent in the machine's design. But few MIGs have the adjustable Inductance. Inductance is part of the personality of a MIG welder. Its one reason that some people prefer the arc of one brand over the other since people develop personal preferences in arc performance. With that in mind, having an adjustable Inductance serves several functions:

- 1) The Inductance allows the user to dial the machine to a performance level that the user is accustomed to. This helps if multiple users are present and improves the operator's performance with the welder.
- 2) The Inductance can help improve control and weldability in out-of-position welds (weld positions other than flat) without having to change other parameters.
- 3) Different shielding gases require different levels of inductance for optimum performance. This is particularly true when welding in the Pulse-MIG modes. The arc force improves performance with different gas mixes by being able to adjust the arc to render the best and smoothest possible arc for the shielding gas being used. Induct-

ance allows this machine to have excellent arc performance when pure CO₂ is used in non-pulse modes.

- 4) The inductance can improve weldability of thinner metals without having to step down a size in wire. While ultimately there are limits to what any given wire can weld on the lower end of its range, it does help improve the low amp welding characteristics of the wire diameter.

For the best possible experience welding with the Power i-MIG, adjust Inductance after the Amps and Volts (or Trim/Volt offset if in Pulse mode) have been tuned. This will keep the user from constantly having to hunt for the best balance of the other two adjustments. Usually once a particular arc force setting is selected that is suitable to the user, it will work well throughout the range of adjustments and will rarely require readjustment once set to the operator's satisfaction. However, this is not to say that readjusting the arc force from time to time is not beneficial. When the operator must weld out-of-position, readjusting the arc force control can help reduce clogging of the nozzle and even make the puddle more controllable.

Avoid the temptation of setting the control at the mid-point or even full left or full right without performing a few test welds first. Few users will find these settings to their liking. Turning the Inductance to the minimum setting does not turn the feature off. A good starting point is somewhere between 2 and 3 in standard, non-pulse modes. In Pulse mode, especially while welding aluminum, you may need to start as high as 6 to 7 and increase from there. This will usually produce a desirable arc with for most people and will produce minimal spatter. If spatter becomes a problem and everything seems adjusted properly, always remember to check the Inductance setting. Test and fine tune the adjustment from there increasing in increments of 1 before starting to weld any critical part. The range for this unit is from 1 to 9, in whole numbers.

Burn Back Control.

After the trigger is released on the welder, it's natural for a small extra amount of wire to coast out of the gun. This small amount of extra wire may stick fast in the weld as the molten puddle begins to cool. This will require the operator to break it loose and

BASIC MIG OPERATION

spend time trimming the wire. Even if the wire does not stick in the puddle, it will often be left sticking too far out from the contact tip for a proper restart. Trimming is usually required with a pair of MIG pliers or wire cutter before restarting the arc. With burn back control, however, the arc can be kept energized long enough to continue supplying power to the wire long enough to burn the wire back to the desired length after the wire stops feeding. The timer control located under the cover sets the length of time the that the arc remains on after the trigger is released.

If the burn back control is set too long it can cause the wire to burn back into the tip itself and welding of the wire to the tip. Begin with setting the unit for a little less than a quarter second. If the burn back control is set correctly, it will leave about 1/4"-3/8" wire sticking out beyond the contact tip. If a large ball develops on the end of the wire, reduce the burn back time so that it creates a balance between ball size and stick-out. The short amount of post flow that is built into the programming of the Power i-MIG helps shield while the wire is burning back. This helps control balling and prevents oxidation during burn back. This is a unique feature that is not found in many welders with burn back control. Burn-back control without post flow can cause erratic restarts due to the oxidized or over-balled wire tip.

Even with the burn back control properly adjusted, due to operator error, an occasional quick trim of the wire may be necessary for best arc starts. But overall, when used in a production setting or in a fabrication shop, the burn back control can save on labor and aggra-

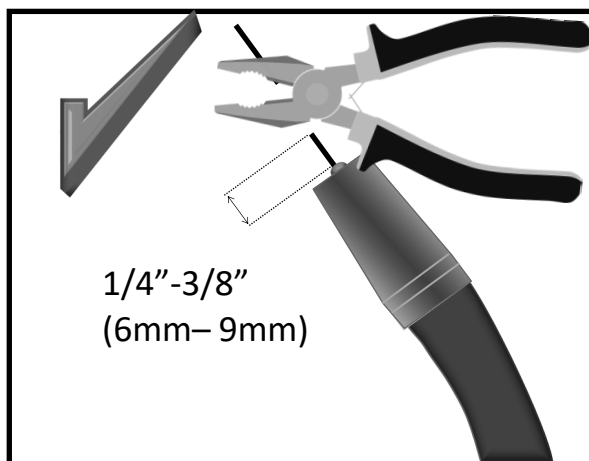

vation.

Starting the Arc and Welding.

Starting the arc is a relatively simple process. Before beginning, the wire should initially be trimmed to between 1/4 to 3/8". Once the wire is trimmed, the gun should be firmly grasped to prevent a phenomenon often referred to as "machine gunning". A light grasp, especially at start, can cause the arc to stutter as the wire pushes back on the gun, lengthening the wire stick-out and creating an irregular start and porous weld.

The end of the wire should be positioned just barely above the metal when the trigger is pulled for the cleanest start. This will position the end of the contact tip about 1/2" above the weld. The gun should be in the vertical position, with no more than 5 degrees lean in either side to side direction. Holding the wire too far off from the metal will result in rough starting and too long of wire stick out.

Once the arc has been established, the gun can then either be pushed or pulled in the direction of the weld. In either case, the gun nozzle should be positioned directly over the weld without angling the wire to one side or the other of the weld as already mentioned. The gun should have no more than 15 degrees lean pointed into (push) or pointed away from (pull) the direction of travel. In most cases a push motion is desired. However, a lot of texts offer conflicting information on whether to push or to pull the gun. In reality, both are correct if used correctly and with each having particular strength and weakness. Either one done with too much gun angle will result in undesirable results. Most open-minded people who are well versed in MIG quickly develop a sense of when to push and when to pull the gun. Even for novices, a sense of when to push and pull the gun comes quickly with a little practice. Pushing can result in shallower penetration but the molten puddle is easier to see and the arc sits easily on the leading edge. It will usually leave a aesthetically pleasing bead. However, be careful to prevent the gun from leaning toward or away from the direction of travel too much as spatter will increase and shielding gas flow may become turbulent, creating porosity in the weld. Pulling will result in deeper penetration, but can result in a narrow bead without much side fusion. It also can leave an undesirable

BASIC MIG OPERATION

humped appearance if not done correctly or if travel is too slow. **Whenever MIG welding with Aluminum, whether with the standard MIG gun or the Spool gun ALWAYS push the gun. During Pulse Welding, a Push angle is recommended wherever possible, regardless of metal type. If using Flux Core, a dragging motion is almost always recommended.**

Weaving (oscillating the torch from side to side in one pattern or the other), particularly a MIG bead, is a topic of controversy as much as whether to push or pull the MIG gun. Stringer beads are often best for novice welders. Stringers are simply straight beads that move forward with little or no side to side travel or oscillation. These will offer the soundest welds for a beginner. Stringer welds leave little or no room for contaminants to enter the weld and are the fastest to produce without creating an opportunity for cold lap. Moving too quickly however with a stringer can create undercut which will weaken the weld. The best policy is to move a slow steady speed, making sure the sides of the weld are filled. If undercut is present, it is either from too much voltage or moving before the wire has time to fill the area the arc has melted.

Think of weaving as a method of “sewing” the metal together. If weaving is of interest to you, start with the basic weave pattern. Simple weaves using one variation or the other of a cursive “e” motion are best to begin with. Other weave patterns can be used of course. C’s, V’s, U’s, Triangles and many more weave patterns can be used depending upon the application. Weaves are employed for a number of reasons. Weaves are often considered to have a more pleasing appearance and can help bridge gaps where fit up is a problem. A weave is also frequently used to manage heat build up. For example: when welding vertically weaves are almost always used to prevent the molten metal from sagging due to the force of gravity. The major drawback of weaving is that it introduces a greater possibility of getting inclusions and other forms of contamination in the weld. Properly done weaving is a valuable tool, but it must be practiced before employing it in any structural or critical application.

Metal Cleaning.

MIG welding requires a well prepped surface to ob-

tain a sound weld. The removal of paint, rust mill scale, or other contaminate such as grease should be done before welding. Stick welding is more forgiving of rust and mill scale, but when MIG welding, contaminants will result in porosity and inclusions in the weld, weakening it. A grinder will usually prep the metal sufficiently to remove oxidation and paint. However, to remove grease, a degreaser such as acetone should be used. Do not use any degreaser such a brake cleaner with chlorinated solvents or death or serious injury may occur! Pre-Clean stripped Aluminum with a dedicated Stainless Steel Brush to remove oxidation, even if metal is bright and appears clean. Aluminum will create an oxide layer quickly. Aluminum such as diamond plate tread with mirror finishes has an oxidized surface. Finish Aluminum with Acetone, or Aluminum cleaner designed for welding.

A Steel MIG wire such as ER70S-6 or ER70S-2 includes a sufficient level of deoxidizers such as silicon and copper that are formulated to allow it to handle minor to moderate amounts of rust and mill scale. These deoxidizers will float out most moderate amounts of contaminants out of the weld and will appear in the usual form of glassy like deposits on top of the cooled metal. They are easily brushed off before starting the next pass. They should not be welded over. Any pinholes that appear are a result of trapped gas in the weld and should be ground out before the next pass. It should be noted that some MIG wires such as ER70S-3 have low levels of deoxidizers and must be thoroughly cleaned and ground before welding.









Multiple Pass Welds.

One of the common misunderstandings that people have when beginning to MIG weld is that if the welder has the power, then a single heavy pass will do to weld up in a single pass. This is a primary way to introduce cold lap and incomplete fusion to the weld. Single pass welds should not exceed 1/4” even with the heaviest wire the welder is capable of handling. A thick pass may also begin to cool before contaminants and gas pockets have the time to float out to the surface. It’s far better to make multiple smaller passes to complete a plate weld for a higher quality result. For best results, this requires that most joints 1/4” and over be prepared with a grinder to accept multiple weld

BASIC MIG OPERATION

passes. The weldment edges should be ground to form a V, U or J shaped groove to create a recess where the welds can be welded one on top of another. For welding with .035" wire and under, create a bead no thicker than 3/16" in a single pass, no more than 1/8" with .030" wire, and with .025" wire and smaller no more than 3/32 for best results. This will help maintain proper fluidity of the weld and prevent gas from being trapped in the weld and give time for any minor contaminants to float out of the weld. It will also help to maintain reasonable forward travel speeds. Too slow of travel speeds will create excess build up and can tend to create cold lap at the weld toes resulting in poor tie in. One issue created with a weaving technique even if the metal deposited is the correct thickness is that it can slow the forward progress down. If weaving is too wide, one side of the puddle will cool and oxidize before the torch is brought back across to that side. This is a point where porosity and inclusions can be introduced.

BASIC MIG OPERATION

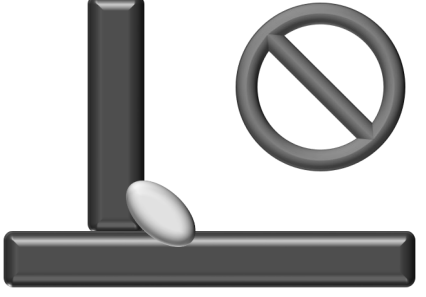
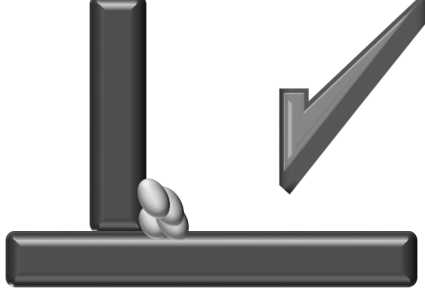
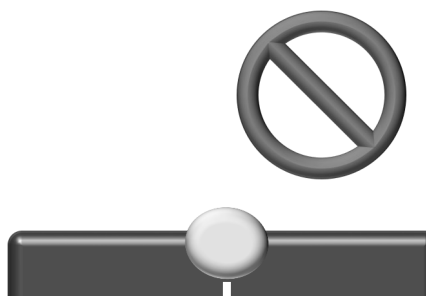
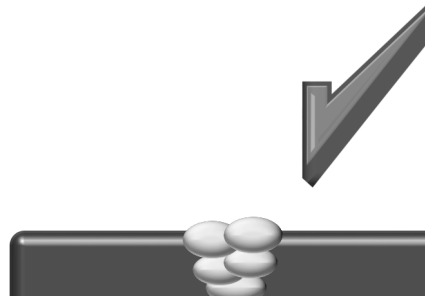

V-GROOVE (60-80°) 	DOUBLE V-GROOVE 	<p>Besides a butt joint and lap joint which are often used for thinner metal gauges, consider using one of these groove joints for best welding results. When grinding or cutting the bevels, especially with a single V-groove, it may be beneficial to leave a small land with a gap between the joint to achieve full penetration. In this case a temporary backer plate can be used to support the bottom of the weld to create the root pass. The root weld will weld the backer to the main plate. This backer can later be ground or cut off. However, in many cases a plain open root can be used as a backer plate adds to the time and labor involved. A knife edge is also acceptable so long as the joint is fully penetrated when the weld is completed. Open root gaps without a backer can range from 1/16" to 1/8" depending upon wire diameter and application.</p>
U-GROOVE 	DOUBLE U-GROOVE 	
BEVEL GROOVE 	DOUBLE BEVEL GROOVE 	
J-GROOVE 	DOUBLE J-GROOVE 	
JOINT PREPARATION		

 ≥ 1/4" Fillet	 ≥ 1/4" Fillet
 ≥ 1/4" Butt Joint	 ≥ 1/4" V Joint

When welding material 1/4" and over be careful about trying to put too much metal down in a single pass. Use multiple passes to complete the weld along with any necessary joint preparation especially with wires of smaller diameter. As metal thickness goes up, so does the number of required passes. Depending upon the wire diameter and power settings used, a 1/4" joint may only require 1 or 2 passes to complete. A 3/8" joint in plate metal or pipe will require not only beveling but 4 to 6 overlapping weld passes including a cap and root pass.

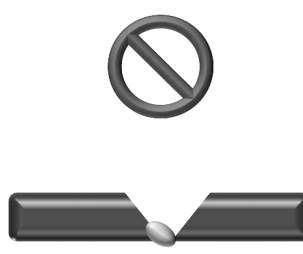
BASIC MIG OPERATION

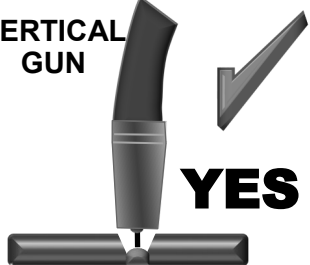
 <p>NO</p>	<p>Problem: Gun is not being held vertical from side to side. Wire is not being directed to the center of the puddle. This concentrates heat on one side of the joint and results in poor fusion on the neglected side. It also can create more buildup on one side of the joint than the other.</p> <p>Correction: Hold the gun so that the angle of the neck stands perpendicular from side to side.</p>	
--	--	---

<p>VERTICAL GUN</p>  <p>YES</p>	<p>Correct Technique: The gun is held in a near vertical position. A variance of 5 degrees or less is acceptable from side to side. The purpose is to prevent the arc from being concentrated on one side of the weld joint or the other. This balances the heat on both sides of the joint and keeps the bead centered. Don't confuse this with push or pull angle in the travel direction.</p>	
--	---	---

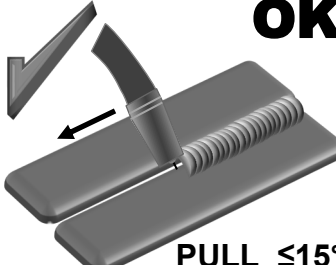
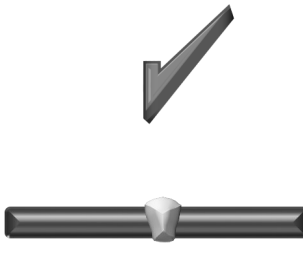
 <p>OK</p> <p>PULL $\le 15^\circ$</p>	<p>Correct Technique: The gun is angled toward the back of the weld when traveling forward. This angle should not exceed 15 degrees. This provides a narrower but more deeply penetrating weld. Use this method when Flux Core wire is being used. Use this method where the unit may be reaching its maximum welding capacity. Not for use with Aluminum wire.</p>	
---	--	---

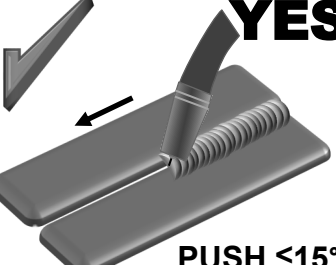
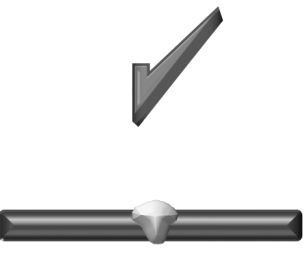
 <p>YES</p> <p>PUSH $\le 15^\circ$</p>	<p>Correct Technique: The gun can be angled toward the front of the weld when traveling forward. This angle should not exceed 15 degrees. This provides a wider and generally more pleasing weld. However it is shallower penetrating. This method typically allows a much better view of the arc. Use for most types of welding unless deeper penetration must be achieved.</p>	
--	---	---

BASIC MIG OPERATION

	<p>Characteristics: Concave weld, poor filling, possible undercutting resulting in weak weld.</p> <p>Possible Causes: Voltage too high, not enough wire speed, too short of wire stick out, wrong gun angle.</p> <p>Remedy: Decrease voltage, use push motion, increase wire speed.</p>
---	--

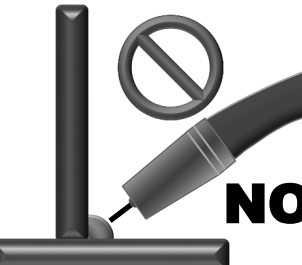
	<p>Characteristics: Small Convex weld possibly with bulging sides/cold lap and/or an inconsistent arc.</p> <p>Possible Causes: Not enough Voltage or Amperage. If weld is ropy and thin without bulging at the toes, travel speed is too fast or using a pull technique.</p> <p>Remedy: Increase voltage and amperage, slow down to fill joint more. Use push technique.</p>
---	---

	<p>Characteristics: Large convex weld with bulging at toes, weld legs exceed thickness of the metal being welded.</p> <p>Possible Causes: Not enough voltage, too much wire speed, overfilling due to too slow of forward travel speed, and/or poor weaving technique.</p> <p>Remedy: Increase voltage, increase forward travel speed, reduce weaving width.</p>
---	---

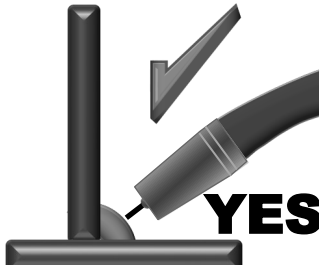
	<p>Proper Weld Characteristics: Weld is slightly convex, weld legs (vertical and horizontal width of weld) are equal in length and match the thickness of the metal being welded. No traces of undercutting, Proper tie in of the weld at the toes with no cold lap. Weld is not overfilled or under-filled with no significant amounts of spatter, soot or contaminates around weld. Weld is not oxidized and is bright.</p>
---	--

PULSE MIG OPERATION

The Power i-MIG 253DPi pulse design features both Single and Double Pulse wave forms that feature synergic control of the pulse parameters. Simply put, this means that the complicated parameters required to perfect the pulse action of the welder are controlled largely by an algorithm designed and tested by qualified welding engineers to provide smooth and well-regulated welding performance. To understand the Everlast Pulse MIG design and setup, it is important to recognize and discuss basic types of Pulse MIG welding and how each is performed and managed.

The Types of Pulse MIG Welders. There are many different types of pulse MIG welders. Every brand has their own type or types of pulse MIG welders. Over the years, pulse MIG welders have changed in design and function and multiple types of Pulse MIG may be represented under one brand. Many times it is difficult to pinpoint the differences in the pulse function from generation to generation or model to model as many companies prefer to explain the effects rather than the functions. There are nomenclature differences as well from brand to brand and model to model. One function may be called by one name by one company, while the same function is called by another name by another company. Some offer more fine tuning control over the parameters than others. Over the years pulse MIG welders have steadily evolved. This has created a lot of confusion and misunderstanding in the industry by users about what pulse MIG welding is and what it is capable of. Training seminars provided to dealers of one type of brand may indeed teach that a Pulse MIG product feature is unique or special by trademarking a name of a type of Pulse or Pulse function, while another brand has the same exact fea-

ture but is called by another name. It has led to a lot of confusion in the industry. However, to be clear, there are two major categories of pulse MIG welders: single (or simple) pulse, and double (or pulse-on-pulse) pulse. With most single-pulse MIGs, the power is pulsed between two preset values, creating a simple, modified square wave output of DC. With a double-pulse MIG, the unit simply pulses between a higher layer and a lower layer of single pulse MIG. In the most simple terms, this creates a more complex wave form which looks and sounds different than a single pulse square (up and down) wave form. The main advantage of using the double pulse MIG, is potential for aesthetically pleasing welds that closely approximates the “stack-of-dimes” look desired in high-quality finished welds. When it is properly set-up, a Double Pulse MIG creates a pattern of defined separation in the cooled weld similar to what you’d expect to find in a well-crafted TIG weld. Though the completed look of a double-pulse MIG weld may be similar and appealing to TIG, a trained eye can still spot the difference. However, whether or not it is 100% identical looking to TIG, double-pulse MIG provides a visually appealing weld that stands up to the scrutiny and expectations of most customers. Depending upon how the unit is fine-tuned and how well practiced the operator is, an additional measure of heat control can also be gained through the double pulse MIG process.

The Basic Theory and Purpose Behind Single Pulse-MIG. Regardless of the type of pulse MIG we are referring to, *most* single-pulse MIG welders are cycling several times a second between high and low values of voltage. Many single pulse-MIG welders cycle between 20-500 Hz. This allows good control over the

PULSE MIG OPERATION

heat being put into the weld and over the directability of the arc. The basic reason for using a single-pulse MIG is to prevent overheating of the weld metal while maintaining a rapid deposition rate that does not compromise fusion of the base metals. Single-pulse MIG welding is intended to be performed in pulsed-spray mode. Pulsed-spray is a modification of the Axial-spray mode, where the metal actually pinches off before the wire touches the weld puddle. During the Axial-spray mode, the arc should never short circuit. Axial-spray is accomplished by using higher volts and amps than would be used in a short circuit transfer process. By doing so, this forces the wire to pinch and form a steady stream of molten droplets somewhere between the weld puddle and contact tip. These droplets travel rapidly across the arc and direct into the puddle. The result is fast travel speed and a smooth, quiet arc that is not much more than a steady, quiet "hiss". The down side is that the puddle is hot and uncontrollable if used out of the flat position. The puddle will simply run off, or melt through when trying to keep enough metal held in place.

When single pulse mode is engaged, the wire continues to spray, but the Voltage drops low enough to fall out of the range required for Spray but not long enough for any metal to be deposited. The goal is one pulse per droplet of metal. The drop in voltage during the pulse allows the puddle to cool between the high stage portion of the pulses returns. The result is no longer a quiet hiss, but a rather unique sound that has often been compared to an "angry bee" or a "swarm of hornets". More importantly, the puddle becomes stable, heat is controlled, and out of position welding becomes possible.

Historically, the most common applications for single Pulse-MIG welding are found in Aluminum or Stainless Steel fabrication or repair. Currently, though, single Pulse-MIG welders are being used to MIG braze with silicon bronze in auto body repair shops. MIG brazing is being used where auto manufacturers are requiring this as process to repair and join modern high carbon steels that are heat sensitive and prone to cracking. The brazing process creates a strong joint without having to bring the Carbon steel up to a melting point.

Pulsed-spray is also used with mild or carbon steels to allow out of position welding while maintaining useful production welding speeds without sacrificing penetration. In comparison, Short-circuit transfer is a cooler and slower MIG process where the MIG wire has to extend out from the contact tip and travels down and into the puddle before the arc shorts and the wire melts in a relatively forceful "blast". Pulse MIG combines both processes and retains the best attributes of both short-circuit and Axial-Spray welding.

In steel and stainless use, whether in Pulsed spray or Axial spray special gases which enable a lower transition point into Spray should be used to be controllable and practical. These gases are much higher in Argon. The recommended gas is 90/10 Ar/CO₂ for steel. However, Gases may be used as high as 98/2 Ar/O₂ or as low as 80/20 Ar/CO₂. For Stainless, numerous combinations can be used, but the factory recommended setting that yields the best results is 98/2 Ar/CO₂, although 98/2 Ar/O₂ may be used, or a Special Tri-MIX designed for Spray. As for Aluminum, most MIG welding of Aluminum is already done in spray mode to

PULSE MIG OPERATION

prevent incomplete fusion. All MIG welding is done, regardless of transfer method is commonly done with Argon, or more rarely, an Argon/Helium mix. Copper/Bronze should be welded with 100% Argon.

Most double Pulse MIGs are largely used for Aluminum welding, though they can be used for Stainless Steel or Steel welding or Bronze brazing. The Double Pulse MIGs, are usually completing full cycles at a frequency of 10 Hz or less (though there may be many single pulse cycles within one full Double Pulse cycle). Double Pulse MIG is commonly associated with the “TIG” look, with well defined ripples. The heating and cooling is done at a level and speed that allows the weld to cool and begin to freeze somewhat between the high pulse stages of the pulse cycle without extinguishing the arc or completely losing the molten puddle. This is done by two alternating between two layers of single pulse and can offer aesthetic advantages over single pulse MIGs. While heat management is also attainable, double pulse capable MIGs are sought after as they can mimic the style and look of TIG while offering improved production levels. The skill level required by double Pulse-MIG to obtain competent welds is much lower than TIG. The single pulse is not comparable in look to the look of the double pulse MIG weld, even though some refinement of the weld is possible in a single pulse MIG. The main goal of Single Pulse MIG is to improve heat control, gain weld speed and give directability to the arc.

Basic synergic MIG applications and its use in pulse MIG. Both pulse types have many variations from brand to brand and model to model. But most modern forms of pulse are complicated to set manually, with most of the pa-

rameters taken out of the control of the user, and only allow minor fine tuning by the user, if any at all. The controls that do exist in these pulse models are often not clearly defined in their function or adjustment values. Older Pulse MIGs from generations ago, allowed more adjustments. However, these older transformer based and early inverter based pulse MIGs were often too difficult to set without considerable training and experience. Newer generations of Pulse MIG welders, including the Power i-MIG 253DPi are controlled by digital programs which are programmed by the factory for optimal performance based off of engineered testing and user experience. This type of control is considered to be “synergic”. New synergic MIG welders keep frequency, voltage, inductance, wire speed and a few other parameters all within a tightly controlled range that prevents the user from going too far astray. Synergic MIG does not just extend to Pulse MIG welding. It can be used in non-pulse forms of MIG as well. The main idea, is that the unit automatically computes and sets up the output parameters based off of the operator’s input of information, such as wire-type and wire diameter.

While Synergic Pulse MIG is a great development that helps the untrained welder to learn and setup the equipment quickly, the lack of commonality in terms, clearly defined references to values, and even differences in the nomenclature make employing Pulse MIG welders for jobs that require strictly defined parameter values quite difficult. What’s more, settings are hard (if not impossible) to transfer across brands or model variations if a procedure has been qualified using one brand or model of welder. However, with these negatives aside, Synergic Pulse-MIG is quickly find-

PULSE MIG OPERATION

ing acceptance and gaining wider understanding. As more Pulse MIGs are employed, even term standardization has begun as training programs are being instituted throughout the industry to reflect market changes in welding procedures.

Everlast's Synergic Pulse MIG Design. **Pulse is, in the simplest of terms a cycling of a welder between two different set levels of power, one at a high value (Pulse Peak) and one at a lower value (Pulse Base) setting.** Everlast's approach to pulse MIG design is similar to other brands and models of pulse MIG welders. Although similar, it is a bit different as well in the fact that more effort has been made to simplify the nomenclature associated with the unit's controls. We have also tried to simplify operator input without compromising the basics of Synergic operation. In Synergic Single Pulse MIG mode, the Power i-MIG 253DPi can be compared to other types of Synergic single-Pulse MIG welders in the fact that the pulse wave shape is considered "simple" because it is pulsing between two defined values that are optimized by the unit's programming.

The Power i-MIG 253DPi features both single and double pulse modes. As previously stated, during the pulse MIG process (single or double) there are two alternating "values" that are being pulsed. Depending upon the weld process type, this "value" can Pulse either Volts or Volts and Amps together. In the single pulse mode the welder pulses between two different Volt levels. In double pulse MIG, it pulses between two alternating layers of single pulse, which include separate settings for Amps and Volts. For comparison, a TIG welder operating in Pulse Mode pulses Amps only. By pulsing voltage, you are managing heat by creating an

arc that preserves the best characteristics of the lower voltage values and of the higher voltage values with a lower overall heat input.

Voltage, as used in the MIG welding process, controls the arc length, which in turn controls arc cone diameter. A wider arc cone will create the impression of a "hotter" weld as the wire is burning back to a more distant height from the weld puddle. A higher voltage will also allow the metal to flow more readily (wet-in), leading to a wider, flatter bead. But voltage set too high can also be a contributor to spatter, burn through and arc instability. A lower voltage value can help control burn-through wet-in, and can prevent too wide of a weld bead. But if the voltage is too low the bead profile may be too narrow and too high (often referred to as a ropy weld).

As you use the Everlast welder in pulse mode, the average voltage value is roughly between the two voltage values selected by the programming. The idea is to gain the arc control provided by the lower voltage while gaining the wet-in. property and speed of the higher voltage. This is further fine tuned via the use of Voltage Offset (Trim) control. Keep in mind though, you are not directly setting the independent Peak and Base Voltage with this control. You are only setting a relative value of -5 to +5. The welder automatically selects the Peak and Base voltage based off your selection and input of wire diameter and wire type (alloy/metal selection), and metal thickness (Amps).

This also simultaneously optimizes the speed at which the pulse operates (frequency). Frequency (Hz) yields the added bonus of more a directable arc and a more desirable bead pro-

PULSE MIG OPERATION

file. It also automatically sets a balance of time that is split between the two levels of Voltage. Each half cycle of the pulse has a “duration” or length. The high and low Voltage levels can vary in length during the cycle. Consider this a balance of time between the two that can change, where the one can stay engaged longer than the other during a single pulse cycle. See the examples below for further explanation:

EXAMPLE: SINGLE PULSE CYCLE

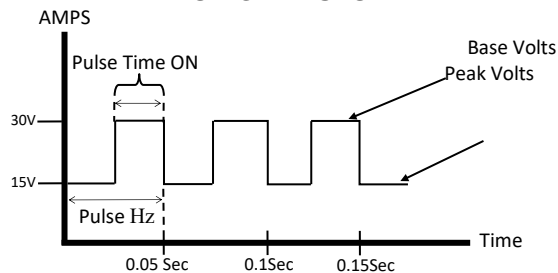

EXAMPLE: SINGLE PULSE BALANCE

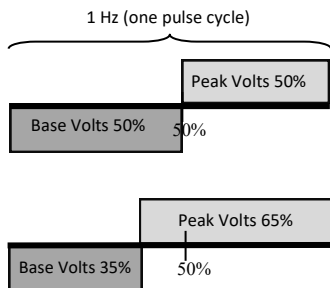

Keep in mind that while these functions are discussed, they are automatically set by the Unit's programming based off of the User inputs of Wire diameter, Wire Type and Metal Thickness (Amps). These are discussed only to help further the understanding of what the Pulse is and does. The Single Pulse MIG has 3 basic parts of the pulse. **When judged by itself, each pulse control function has a specific effect on the weld.** But each pulse function can also have an overlapping effect of another pulse function. This depends upon how the individual pulse function is adjusted rela-

tive to the other two remaining functions. Due to the complexities and endless combinations of the pulse settings, the unit is programmed with an algorithm that has been determined to offer the best range of control and remove settings that would be unproductive and non-workable. Though this may sound confusing at first, a little practice will make sense out of it. Even those these functions are controlled by the synergic programming and are out of the user's control, the two main purposes in discussing the components of that make up a pulse cycle is to make the user aware of the complexities surrounding Pulse and to give better understanding of the mechanics of the pulse.

Although these settings are factory “optimized” by an algorithm, that does not mean that the settings are going to be perfect for every individual or every application. To further fine tune the pulse after you input values for wire type, wire diameter and metal thickness (Amps), you can use the Voltage Offset feature. The range of adjustment is from – 5 to +5. This Offset feature is also known as Trim. The Voltage Offset simply skews the factory settings for the Pulse voltages up or down, effectively changing arc length, heat, and puddle fluidity.

Due to the different gases, operator styles and welding positions used, the Offset can be used to “tune” the welder to the best operating settings. As a “best-practice” policy, start low in the range, around –4 to –3 and increasing one whole number at a time until the operation is improved. After a “close” setting is found, further tune in .1 increments. Using a wider adjustment increment than this will often cause you to skip past a ideal parameter

PULSE MIG OPERATION

setting without giving you an indication that you may be nearing the “sweet spot” for the setting. As you adjust this setting, you will notice a change in arc quality and in sound. This is normal. Resist the temptation to go too far toward the positive end of the scale or burn-back and tip melting will become an issue. This unit is programmed for using Standard shielding gases designed for use with Pulse MIG. Different gas mixes may be used however. Each gas blend will result in a different setting of the Voltage Offset feature. As more CO₂ is used in the shielding gas (always use 20% or less), you will need to increase the value of Voltage Offset. Lower concentrations require less Voltage Offset.

Remember, the pulse feature is intended to be used to control heat input and improve out of position welding capability without creating large sacrifices in travel speed or penetration. **Even before attempting to set the voltage offset, begin by setting wire speed feed/amperage to match metal thickness.** Usually this is 1 amp per .001” of thickness. This is an old rule of thumb and is not accurate in every case. You will notice that when pulsing the unit actually deviates from the settings selected because it is averaging the pulsed values to compensate. This is not a defect. With synergic Single Pulse, keep in mind that the Amps control penetration and too many amps can produce burn through. If in doubt, use the wire manufacturer’s suggested settings found on the packaging or in their published materials. In the absence of these references, if you do not know an approximate setting for Amps, you can use the formulas suggested earlier in this manual to determine the approximate wire feed speed/amp value. **After initially set, Amps should only be adjusted again after**

no workable setting for the Voltage Offset or Inductance has been found. Avoid radical changes in Amps. A space of 3 or 4 Amps can yield a much different level of performance.

Below you will find the three Single Pulse parameters that are synergically controlled, and their basic effects on the weld identified along with additional features affecting the performance of the single-pulse feature of this unit.

Double Pulse Explanation. The double-pulse features more manual control over the weld cycle than the Single Pulse does. However, it is still considered to be synergic in function. This is because the Double-Pulse relies upon the Synergically adjusted Single Pulse. The Double-Pulse is simply two separate settings of Single Pulse, which alternate from .1 to 9.9 times a second. The Peak Pulse value for the Double Pulse is set just as you would with the Single Pulse. Both Amps and the Voltage offset can be adjusted. The Base Pulse Value for the Double Pulse is set identically. The programming of the machine sets each half of the pulse cycle synergically. This “layering” of the pulse creates a heating phase and a cooling phase during one cycle of the Pulse. The Heating stage (notated on the machine as Peak LED) provides the primary melting and advancement of the weld puddle. The Cooling stage, or the base (notated as the welding LED on the machine) keeps the arc going, but the puddle is discernably cooler and the metal begins to solidify, creating a single ripple. **Do not try to set the base as the higher value. Set the Peak as the higher value and the Welding setting as the lower, base value. Doing so may confuse the operator and the programming of the machine, resulting in poor weld**

PULSE MIG OPERATION

performance.

To set Amps properly in the Double Pulse, first set Peak Pulse amps as you would for welding in Single Pulse normally, and up to 20% higher if desired. Begin to set the Base amps (Welding LED) with an Amp setting that is 50 to 75% of the Peak Amps. Do not change or adjust the Volt Offset unless needed. Keep the Volt Offset value the same in both Peak and Base portions.

The Frequency of the Double Pulse results in regulating the spacing of the ripples in the weld. A slow frequency will yield large, coarse ripples, while the faster frequency will begin to refine and tighten up spacing between the ripples. To achieve TIG like results, try setting the Pulse to 1 to 3 Hz. A steady travel speed and a close watch on the puddle will give good results initially. With practice, the results can be improved by manipulating the torch in time with each double pulse cycle. This is accomplished moving forward followed by a brief pause timed to coincide with the up and down cycles of the weld.

The Pulse Time-On is similar to the Pulse-Time On featured in the example on page 44. However, you are simply skewing the time the pulse spends welding in the high stage of single pulse setting against the time the pulse spends welding at the low pulse setting. Increasing the Pulse Time-On increases the heat put into the weld and reduces the freezing action if the pulse hertz. Penetration will be deeper. Decreasing the Pulse Time-On increases the cooling effect, and definition but may also reduce penetration and travel speed. For balanced, even look without sacrificing travel speed, consider setting Pulse Time on to

40 to 60% as an initial setting range.

Pulse MIG and Inductance. Whether in Single Pulse Mode or Double Pulse Mode do not forget about the value of Inductance. It is very important to the function of the Pulse Mode. See previous comments regarding the Inductance settings. Remember that if you are getting a long arc and the wire wants to burn back into the tip while actively welding, it is likely that the Inductance is too low. This effect will be greater while welding Aluminum. For Aluminum set Inductance to 5 and turn up from there. If spatter is noticed, it can be a product of having the Inductance set at one extreme or the other. It also can be from having the Amps set too low.

Special Note concerning Synergic Pulse operation with the spool /push pull gun: Make sure if you purchase a spool gun or push pull gun for operation with this unit, that the Parker version of the spool gun is purchased. Our units are designed to work with the Guns we designate. We do not offer support for other brands or attempts to connect other brands since fittings, torque, voltage and ohms of other brands of guns may differ.

MIG Control Features of the Power i-MIG 253DPi

Gun Operation and Features Controlled in Standard Non-Pulse MIG Mode

Gun Trigger Mode	Pre-Flow (.S)	Hot Start	Peak Pulse	Frequency (Hz)	Pulse Time On (%)	Inductance	Welding Amps/Volts	End Arc Amps/Volts	Burn Back Volts	Burn Back Time (S)	Post Flow Time (S)
2T	X					X	X		X	X	X
4T	X					X	X	X	X	X	X

Gun Operation and Features Controlled in Synergic Non-Pulse MIG Mode

Gun Trigger Mode	Pre-Flow (.S)	Hot Start	Peak Pulse	Frequency (Hz)	Pulse Time On (%)	Inductance	Welding Amp/Volt-Offset	End Arc Amps/Volt-Offset	Burn Back Volt-Offset	Burn Back Time (S)	Post Flow Time (S)
2T	X					X	X		X	X	X
4T	X					X	X	X	X	X	X

Gun Operation and Features Controlled in Synergic Single-Pulse MIG Mode

Gun Trigger Mode	Pre-Flow (.S)	Hot Start	Peak Pulse	Frequency (Hz)	Pulse Time On (%)	Inductance	Welding Amp/Volt-Offset	End Arc Amps/Volt-Offset	Burn Back Volt-Offset	Burn Back Time (S)	Post Flow Time (S)
2T	X					X	X		X	X	X
4T	X					X	X	X	X	X	X
4TSPCL	X	X				X	X	X	X	X	X

Gun Operation and Features Controlled in Standard Double-Pulse MIG Mode

Gun Trigger Mode	Pre-Flow (.S)	Hot Start	Peak Pulse	Frequency (Hz)	Pulse Time On (%)	Inductance	Welding Amp/Volt-Offset	End Arc Amps/Volt-Offset	Burn Back Volt-Offset	Burn Back Time (S)	Post Flow Time (S)
2T	X		X	X	X	X	X		X	X	X
4T	X		X	X	X	X	X	X	X	X	X
4TSPCL	X	X	X	X	X	X	X	X	X	X	X

The welder only allows certain combination of functions and settings to be used with each welding process. In non-pulse modes, the 4T Special function is not needed and therefore blocked from operation. In the graph above, the "X" represents an accessible feature in that mode.

MIG Control Features of the Power i-MIG 253DPI

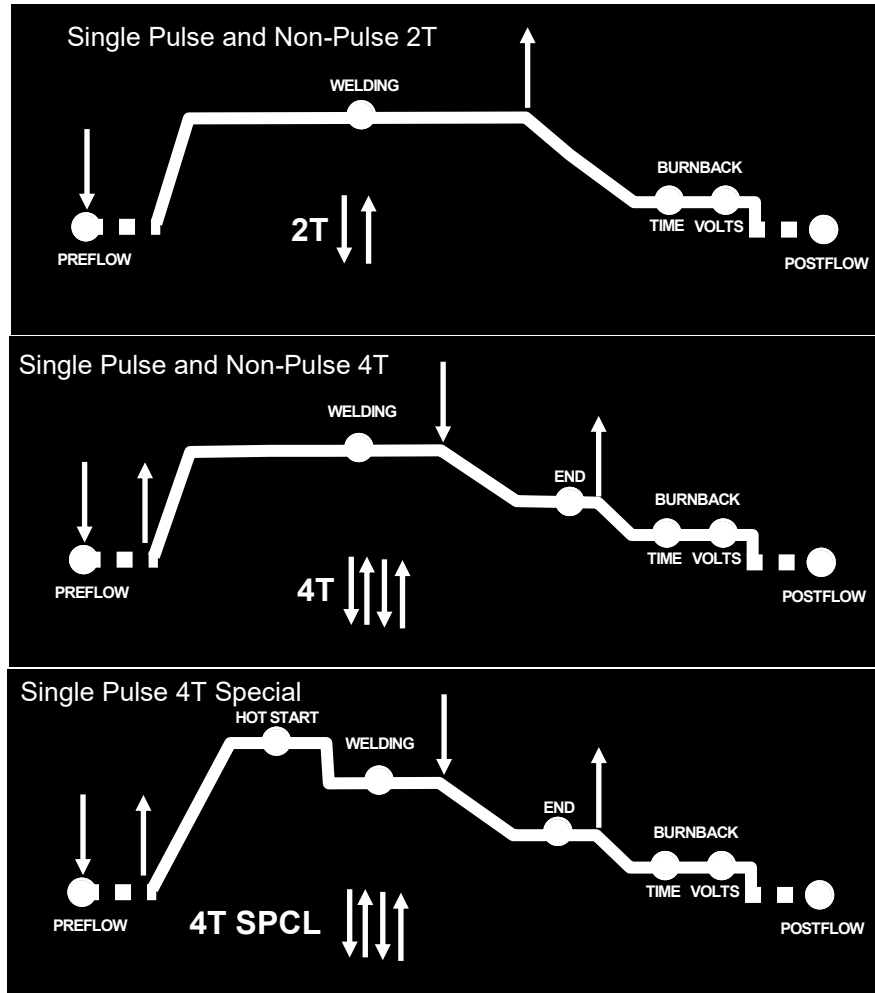

The graphical representation above depicts the motions of the MIG Gun trigger in relation to the welding mode. Each movement of the MIG gun trigger signals the unit to start a new phase of the weld cycle. A “press” of the trigger is one movement represented by the “down” arrow. A “release” of the trigger is another movement of the torch switch and is represented by the “up” arrow. The 4T special mode is not available to standard and synergic non-pulse modes.

MIG Control Features of the Power i-MIG 253DPi

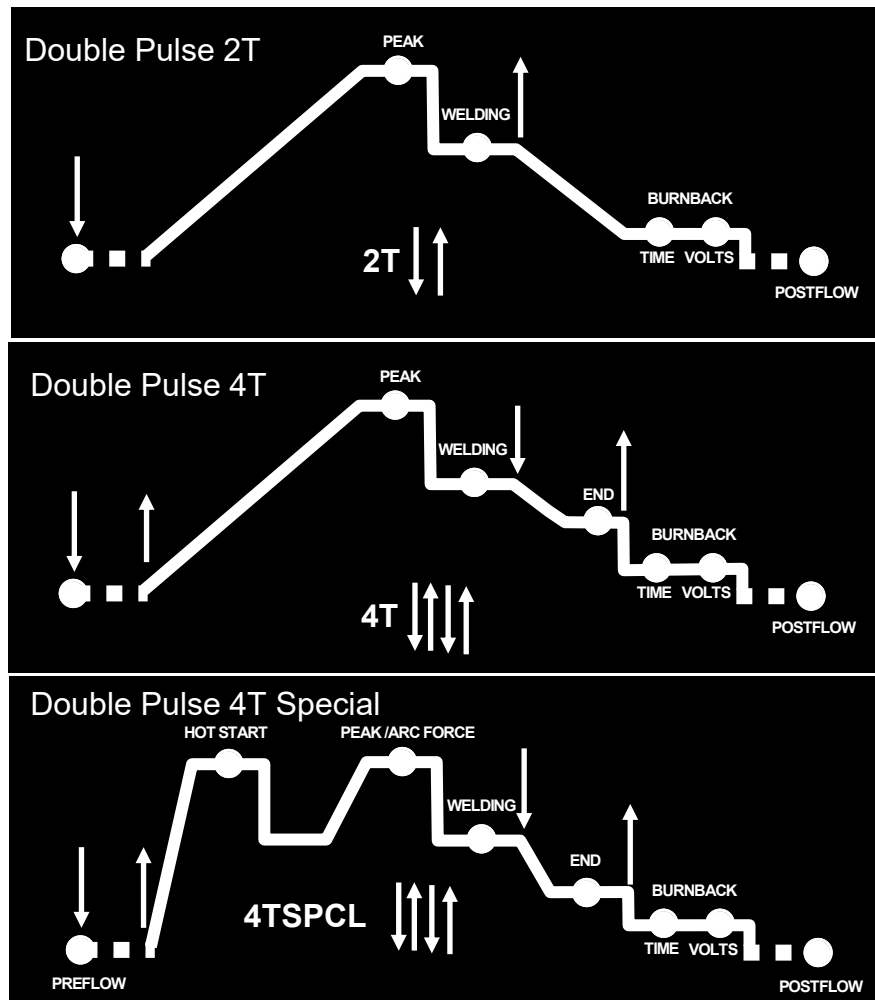

The graphical representation above depicts the motions of the MIG Gun trigger in relation to the welding mode. Each movement of the MIG gun trigger signals the unit to start a new phase of the weld cycle. A “press” of the trigger is one movement represented by the “down” arrow. A “release” of the trigger is another movement of the torch switch and is represented by the “up” arrow. The 4T special mode is not available to standard and synergic non-pulse modes.

Peak Amps offset, range 100-150A

Peak Time offset, range 1.5-3.0ms

Base Amps offset, range 10-40A

Wire Run in Speed, 0-10. 10 is no run in.

Reload factory default settings

The factory synergic settings do allow some corrective adjustment. But they have been carefully chosen for best overall operation and should not normally need to be adjusted. Changing these settings may result in undesirable operation and should be used as a last resort option. However it is realized that some adjustment may be necessary to accommodate special welding situations. Under no circumstances should a novice welder undertake adjustment of these background functions. To access these settings, advance the MIG process button to the Double Pulse MIG function, press and hold for up to 5 seconds until the "setup" button is illuminated and the display changes to read a combinations of letters or letters and numbers. To select the desired adjustment, press either "parameter" select button to change the display to show one of the following letter/number symbols in the display. Use the control knob under the value display to make adjustments to the settings. Then press the process button again to exit. To restore and reload the factory settings (if a detrimental or accidental change has been made) enter the setup mode as described above, and advance the Lod screen. Turn the Volt knob and the display will flash. Once the display flashes, exit setup mode. Turn off welder and turn back on. The factory settings will be reloaded. Again, this adjustment is offered as only a last resort adjustment.

PULSE MIG OPERATION

PULSE WORKSHEETS

Use the following worksheets to save and record your pulse settings for different metals and wire diameters. Or, you may use it to create your own additional spread sheet of settings. Consider using the program memory to save your pulse settings. This is important to ensure rapid setup and repeatability of detailed weld parameters of the pulse. Once the settings have been saved, record the basic settings in the work sheet in case you accidentally save over a favorite program. The following pages can also be used to record settings that you have tried that didn't work so that you can help determine a pattern of settings that are most useful to you.

PULSE MIG OPERATION

Single Pulse MIG Work Sheet 1
Stainless Grade _____

Metal Thickness	Wire Diameter	Hot Start	Amps	Voltage/Offset	Inductance	End A/V	Burn Back Time	Burn Back Offset	PGM #

NOTES:

PULSE MIG OPERATION

Single Pulse MIG Work Sheet 2

Steel Grade _____

Metal Thickness	Wire Diameter	Hot Start	Amps	Voltage/Offset	Inductance	End A/V	Burn Back Time	Burn Back Offset	PGM #

NOTES:

PULSE MIG OPERATION

Single Pulse MIG Work Sheet 3

Aluminum Grade _____

Metal Thickness	Wire Diameter	Hot Start	Amps	Voltage/Offset	Inductance	End A/V	Burn Back Time	Burn Back Offset	PGM #

NOTES:

PULSE MIG OPERATION

Single Pulse MIG Work Sheet 4
Bronze Grade _____

Metal Thickness	Wire Diameter	Hot Start	Amps	Voltage/Offset	Inductance	End A/V	Burn Back Time	Burn Back Offset	PGM #

NOTES:

PULSE MIG OPERATION

Double Pulse MIG Work Sheet 5

Stainless Grade _____

Metal Thickness	Wire Diameter	Hot Start Amps/Offset	Peak Amps/Offset	Pulse Time On %	Pulse Frequency Hz	Welding Amps/Offset	Inductance	End Amps / Offset	Burn Back Time	Burn Back Amps/Offset	PGM #

NOTES:

PULSE MIG OPERATION

Double Pulse MIG Work Sheet 6

Steel Grade _____

Metal Thickness	Wire Diameter	Hot Start Amps/Offset	Peak Amps/Offset	Pulse Time On %	Pulse Frequency Hz	Welding Amps/Offset	Inductance	End Amps / Offset	Burn Back Time	Burn Back Amps/Offset	PGM #

NOTES:

PULSE MIG OPERATION

Double Pulse MIG Work Sheet 7

Aluminum Grade _____

Metal Thickness	Wire Diameter	Hot Start Amps/Offset	Peak Amps/Offset	Pulse Time On %	Pulse Frequency Hz	Welding Amps/Offset	Inductance	End Amps / Offset	Burn Back Time	Burn Back Amps/Offset	PGM #

NOTES:

PULSE MIG OPERATION

Double Pulse MIG Work Sheet 8

Bronze Grade _____

Metal Thickness	Wire Diameter	Hot Start Amps/Offset	Peak Amps/Offset	Pulse Time On %	Pulse Frequency Hz	Welding Amps/Offset	Inductance	End Amps / Offset	Burn Back Time	Burn Back Amps/Offset	PGM #

NOTES:

STICK OPERATION**STARTING METHODS****Tapping Method****Scratch/Match Method**

1. Make sure the unit is turned on and the startup cycle has finished.
2. Select the appropriate Stick icon on the Process Selector.
3. Make sure electrode holder is in in the Positive connector and the work clamp is in the negative connector.
4. Select the Amp level desired. Use table 5 to determine approximate amps suitable for the rod size selected. Consult the welding electrode manufacturer's recommendation as well for proper amperage. No voltage adjustment is available. Select Hot Start Time and Hot Start intensity to improve starting reliability.
5. Use the arc force control to select the desired arc characteristics, creating the desired arc characteristic and amp response needed to maintain the arc. Cellulose electrodes may not have the same arc force behavior as other welding electrodes, but each brand and size will weld a little differently. The arc force control setting will vary from person to person as well, with different rod angles, positions, and arc lengths all factoring into the arc force control performance. If you are new to using a transformer welder, there are some aspects that will seem different. One of the main ones is that the arc is better controlled in most situations by "pushing in" when the arc seems to get weak or unstable and the arc force will kick in as the voltage drops. Holding too long of an arc will signal the inverter to shut down and to terminate welding output. This threshold is shorter than most transformers, and an extremely long arc cannot be maintained. However, with a little practice, the arc will be easy to manage.
6. Strike the arc with either the tapping method or the match strike method. Beginners usually find that the match strike method typically yields the best results.

NOTE: Pay particular attention to the Arc Force setting as it affects the aggressiveness of the arc and the amp response. Though the function of the control is different from Stick to MIG, the effect is somewhat similar. In stick mode, reset the Arc force to approximately 3-5 and readjust it from that point to find the optimum setting. Usually, an increase in the arc force for cellulose based flux welding rods is helpful. Lowering the Arc force setting is generally desirable for rods iron powder/Titania based flux. Too much arc force create overheating of the welding rod, and even cause them to flame up. Too little can lead to sticking and arc snuffing. Don't forget to readjust the arc force when returning to MIG.

General Notes Concerning Operation:

1. While welding aluminum with the Spool gun or MIG gun you must use 100% argon. You cannot use a mix as you would with steel or stainless.
2. While welding aluminum with the Spool gun or MIG gun you must use the next size up tip or a special oversize tip for the wire because the heat will cause the aluminum wire to swell and it will either drag or seize in the tip.
3. While welding aluminum with the MIG process, best results are achieved by using a dedicated stainless steel brush to remove the oxide layer and using acetone or aluminum cleaner before welding to remove any residues. Even though aluminum may appear shiny and clean, it still has an oxide layer and a thin layer of oil left over from the manufacturing process. Some soot will appear in most Aluminum MIG welds but if a lot is noticed, you have either contaminated metal, or insufficient gas flow. You can also induce turbulence by having too much of a torch angle. Start with a 90 degree angle and then lean the gun slightly (about 15 degrees) to the "push" position.
4. Welding aluminum is not a short circuit process. It is a spray transfer process. Spray transfer is a process that is can be used to weld many metals, but in Aluminum it must be used to weld correctly. In spray transfer, the wire does not short out against the weld material. Instead a steady "spray" of droplets of molten metal pinches off before the wire can contact the material. It is a much quieter process. If you are not familiar with the spray transfer process, please research it before you try it. If you incorrectly adjust the welder while welding aluminum in the MIG process, you will burn up contact tips almost instantly.
5. When using the optional spool gun, the amp/wire speed control is controlled at the panel. Contact Everlast directly to purchase the correct spool gun for this welder.
6. Flux Core requires the use of serrated drive rollers. These grip the wire and feed it correctly at a steady speed. Flux Core drive rolls are available for purchase as an optional item.
7. When running this unit on a generator, the manufacturer of the generator must certify it as a having "Clean Power" output. This means the unit produces a truer sine wave and is not a modified sine wave generator and is largely free from harmonic distortion. A clean power generator is usually listed as such, but the manufacturer of the generator should be able to clarify the clean power status of the generator through the technical department of the generator manufacturer. Everlast does not keep a list of approved generators nor does it make endorsements of generators that are listed as clean power output. The generator power requirement for this unit is unit is 8500 continuous watts with a surge capacity of 12,000 watts required.

24 SERIES MIG TORCH



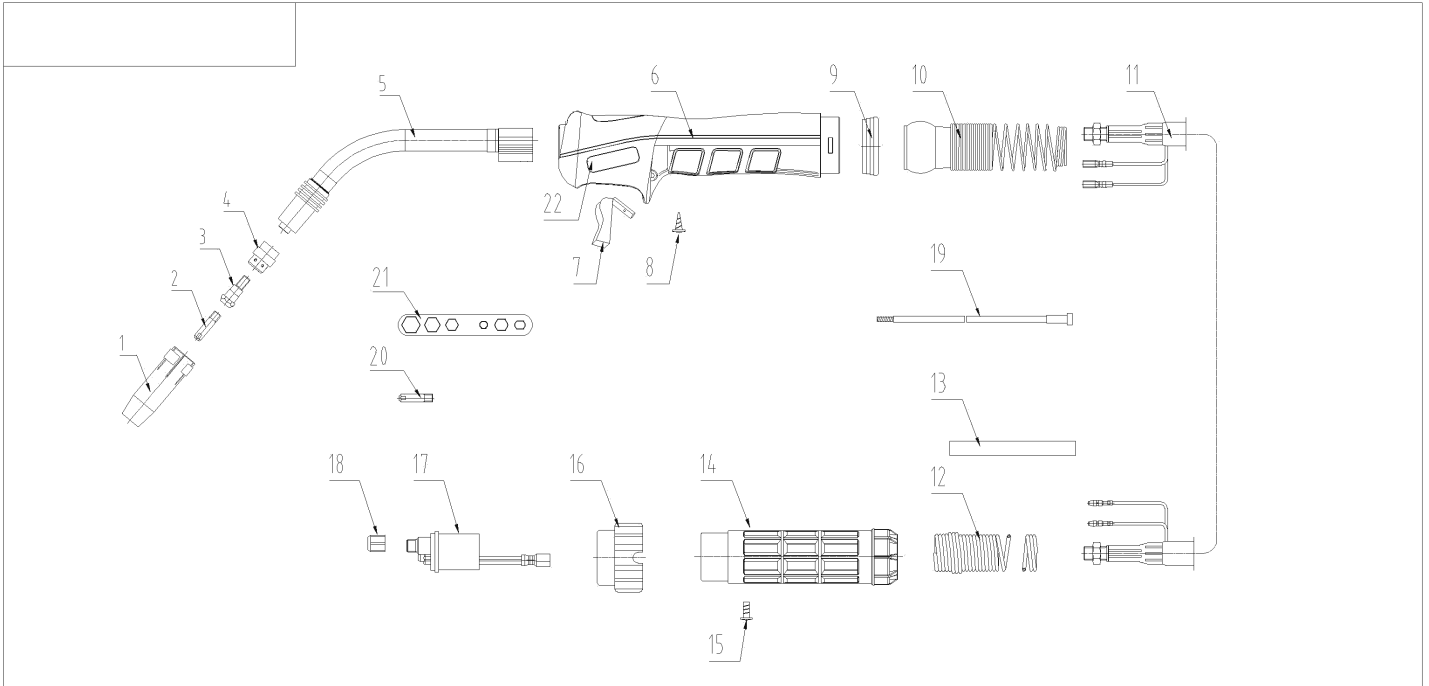







Expanded View



15	IFT0063	SCREW M4X6 UNI 6107	1		22	IFT0104	LABEL ERGO 24KD	1		
14	IHJ0645	Back Box Hole	1		21	ICG6000	SPANNER FOR MIG	1		
13	IHO0050	INSULATOR TUBE/Ø5 M	0.13m		20	ICU0004-08	Contact Tip 0.8/M6x28	1		
12	IFT0897	SPRING FOR CABLE SUPPORT/BLACK	1		19	IIC0560-02	Insulated Steel Liner 1.0-1.2 3.1m Red/TORCH	1		
11	ICN0664	COAXIAL CABLE 25mmq 3m	1		18	IZT0071	Liner Nut	1		
10	IZH0864	Joint With Spring	1		17	ITB0059	Euro Central Adaptor Body/Spring pins	1		
9	IHJ0715	HOUSING FOR HANDLE	1		16	IHJ0070	Gun Plug Nut	1		
8	IFT0874	SCREW D.3x10 UNI9707	3		serial number	drawing number	name	quantity	note	
7	IHO0070	TRIGGER RED	1						range of tolerance	
6	ICV0757	MIG HANDLE BLUE/INNO/GRIP	1						a<6 6-a<30 30-a<120 a>120	
5	ICZ0630	Torch Head 24KD	1						±0.1 ±0.2 ±0.3 ±0.5	
4	ICF0539	White Ceramic Gas Diffuser 24KD	1		marking	places	revised file No	signature	date	description
3	ICU0683	Contact Tip Holder 24KD M6 26mm	1		designer		standardization			reference number
2	ICU0004-10	Contact Tip 1.0/M6x28	2		drafted		craft			material
1	ICS0806	Gas Nozzle Ø12.5 24KD	1		proofread		approval			weight(g)
serial number	drawing number	name	quantity	note	Audit		date	2016-08-15		edition
										A
										page one
										one page in total
										Shanghai Innotec Co.,Ltd

NOTE: Some components may appear slightly different as design/supplier changes are made from time to time. At time of publication, the standard MIG gun provided with Power i-MIG 253DPI is commonly known as the 24 series. Some units may use a 36 series. To determine the series when purchasing parts, the 24 has cooling rings on the gun neck next to the nozzle, and the copper colored nozzle is split and simply slides on. The 36 series nozzle is larger. This torch may be supplied by Binzel®, Trafimet®, or other similar manufacturer. The Innotec® listed above is currently the default supplier of the 36 series. Everlast is not the torch manufacturer, but equips the Power i-MIG units with some of the most proven torches in history. Numerous manufacturers all over the world use variations of these torches. The 24 and 36 Series consumables and most parts interchange from brand to brand within torches of the same series number (except torch handle design and trigger). The widely used Euro-connector on the MIG torch also ensures that the customer can fit and install almost any other type MIG torch if they desire, since most manufacturers offer torches with a Euro connector as an option.

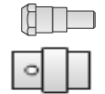
TORCH CONSUMABLE LIST FOR 24 SERIES MIG TORCH

Item #	Part # I	Ref # T	Ref# B	Description	Size	Image
1		MCO300	145.0062	Nozzle	17x63.5mm	
1	ICS086	MC0301	145.0080	Nozzle Std.	12.5x63.5mm	
1		MC0302	145.0128	Nozzle	10x63.5mm	
1		MC0303	145.0174	Spot Nozzle	17x68mm	
2		MD0008-06	140.0008	M6 Contact Tip	.023" / .6mm	
2		MD0008-08	140.0059	M6 Contact Tip	.030" / .8mm	
2		MD0008-09	140.0177	M6 Contact Tip	.035" / .9mm	
2	ICU-0004-10	MD0008-10	140.0253	M6 Contact Tip	.040" / 1.0mm	
2		MD0008-12	140.0387	M6 Contact Tip	.045" / 1.2mm	
3	ICU-00683	MD0138-00	142.003	M6 Contact Tip Holder	26mm	
4	ICF-0539	ME0584	012.0183	Gas Diffuser Ceramic	20mm	
5	ICZ-0630	MF0180	12.0001	Torch Neck		
7	IHQ0070		185.0031	Trigger		
19	IC0-560-02	GM0510-2	124.0025	Liner	.8-1.2mm	

NOTE: At time of publication, the standard torch provided with Power i-MIG 253DPI is commonly known as the 24 series with some models featuring a 36 series torch. This torch may be supplied by Binzel®, Trafimet®, Innotec® or other similar manufacturer. However the consumables and many parts for series 24 torches generally interchange from brand to brand except the torch handle design and trigger. The widely used Euro-connector on the MIG torch also ensures that the customer can fit and install almost any other type MIG torch since most manufacturers offer torches with a Euro connector as an option. This list is provided as a general cross reference and does not guarantee that every variation or type is directly available from Everlast. In the left column, are the OEM part numbers. Trafimet® and Binzel® part numbers are listed as a reference where similar or interchangeable. You can also find the list of stocked consumables for the Everlast website for the 24 and 36 series.

36 SERIES MIG TORCH (Optional) Expanded View

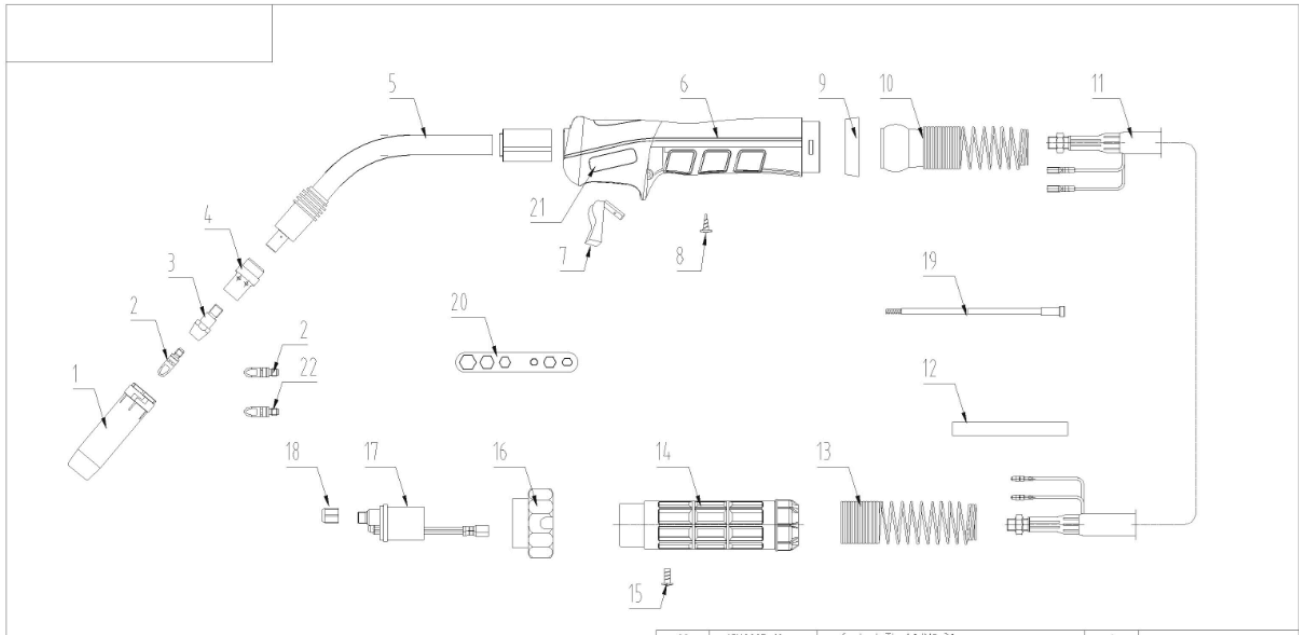

15	IFT0863	SCREW M4X6 UNI 6107	1		22	ICU0005-10	Contact Tip 1.0/M8x30	1		
14	IHJ0645	Back Box Hole	1		21	IFT0167	LABEL ERGO 36KD	1		
13	IFT0897	SPRING FOR CABLE SUPPORT/BLACK	1		20	ICG6004	SPANNER FOR MIG	1		
12	IHD0050	INSULATOR TUBE/Ø5 M	0.13m		19	IIC0598	Insulated Steel Liner 1.2-1.6 3.4m Yellow	1		
11	ICN0678	COAXIAL CABLE 4.2mmø 3m	1		18	I2T0071	Liner Nut	1		
10	IZH0864	Joint With Spring	1		17	ITB0059	Euro Central Adaptor Body/Spring pins	1		
9	IHJ0715	HOUSING FOR HANDLE	1		16	IHJ0070	Gun Plug Nut	1		
8	IFT0874	SCREW D3x10 UNI9707	3		serial number	drawing number	name	quantity	note	
7	IHD0070	TRIGGER RED	1		ICT2998-26					
6	ICV0757	MIG HANDLE BLUE/INNO/GRIP	1							
5	ICZ0889	Torch Head 36KD	1		range of tolerance					
4	ICF0562	White Ceramic Gas Diffuser 36KD	1		a=6	b=a-30	30-a-120	a-120		
3	ICU0687	Contact Tip Holder 36KD MB 32mm	1		±0.1	±0.2	±0.3	±0.5		
2	ICU0005-12	Contact Tip 1.2/M8x30	2		description					
1	ICS0072	Gas Nozzle Ø16 36KD	1		reference number					
serial number	drawing number	name	quantity	note	designer	standardization	craft	approval	audit	
					marking places	revised file NO	signature	date	description	
					drafted	draft	MIG 360 Torch In With Spring Pinc/NO HANDLE/OLD BACK BOX			
					proofread	approval	page one			
					Audit	date	2016-08-15	one page in total		
					Shanghai Innotec Co.,Ltd					
					innotec					

NOTE: Some components may appear slightly different as design/supplier changes are made from time to time. At time of publication, the standard torch provided with Power i-MIG 253DPi is commonly known as the 36 series. This torch may be supplied by Binzel®, Trafimet®, or other similar manufacturer. However the 36 Series consumables and most parts interchange by brand to brand except torch handle design and trigger. The widely used Euro-connector on the MIG torch also ensures that the customer can fit and install almost any other type MIG torch since most manufacturers offer torches with a Euro connector as an option.





















NOTE: Over time, pressure on the drive rolls causes metal fragments from the filler wire's surface to find its way to the gun cable liner. If the wire guide is not cleaned, it can gradually clog up and causes wire feed malfunctions. If feeding difficulty is observed, clean the liner in the following manner:

- 1) Remove the welding gun's gas nozzle, contact tip and contact tip's adapter.
- 2) With an air nozzle blow compressed air through the wire guide. Wear eye protection!
- 3) Blow out the wire feed mechanism and reel housing with dry compressed air.
- 4) Reassemble components. Tighten the contact tip and contact tip's adapter with the spanner included to ensure tightness. Do not overtighten any fittings or stripping of the threads may result.

The MIG torch liner may eventually become worn and will need to be replaced. When welding aluminum with the main gun, a Teflon liner must be used, necessitating a liner change. A spool gun is the preferred method to weld Al. To change the liner:

- 1) Remove the securing nut of the liner (#17) which exposes the end of the wire guide.
- 2) Straighten the gun cable and withdraw the liner from the gun.
- 3) Carefully push a new wire guide in to the gun. Make sure that the wire guide travels all the way to the contact tip.
- 4) Make sure the O-ring at the machine-end of the gun is installed
- 5) Tighten the wire guide in place.
- 6) Cut the liner 2mm from the mounting nut and file the sharp edge of the liner.
- 7) Reattach the gun and tighten all parts.
- 8) Re-thread wire.

TORCH CONSUMABLE LIST FOR 36 SERIES MIG TORCH (Optional)

CODE			Ø		↔	REF	
MC0026		2,5 mm	12 mm	1/2"	84 mm	145.0126	
MC0027		2,5 mm	16 mm	5/8"	84 mm	145.0078	
MC0028		2,5 mm	19 mm	3/4"	84 mm	145.0045	
MC0109		2,5 mm	17 mm		84 mm	-	
MC0110		2,5 mm	20 mm		90 mm	145.0172	
MC0440		light 2 mm	16 mm	5/8"	84 mm		
MC0527		quick release 2,5 mm	16 mm	5/8"	84 mm	-	
MC0540		quick release – light 2 mm	16 mm	5/8"	84 mm	-	
MD0009-06		M6 - Cu	0,6 mm	.023"	28 mm	140.0005	
MD0009-08		M6 - Cu	0,8 mm	.030"	28 mm	140.0051	
MD0009-09		M6 - Cu	0,9 mm	.035"	28 mm	140.0169	
MD0009-10		M6 - Cu	1,0 mm	.040"	28 mm	140.0242	
MD0009-12		M6 - Cu	1,2 mm	.045"	28 mm	140.0379	
MD0009-14		M6 - Cu	1,4 mm	.052"	28 mm	-	
MD0009-16		M6 - Cu	1,6 mm	1/16"	28 mm	140.0555	
MD0063-00		M6 - brass			28 mm	142.0005	
MD0064-00		M8 - brass			28 mm	142.0020	
MD0131-00		M6 - brass			32 mm	142.0011	
MD0132-00		M8 - brass			32 mm	142.0024	
ME0017		plastic			32,8 mm	014.0261	
ME0041		plastic			32,8 mm	014.0021	
ME0417		plastic compound high tech			32,8 mm	-	
ME0517		ceramic			32,8 mm	014.0023	
GM0540		yellow steel liner	1,2 ÷ 1,6 mm	.045" ÷ 1/16"	3 m	10'	124.0041
GM0541		yellow steel liner	1,2 ÷ 1,6 mm	.045" ÷ 1/16"	4 m	12'	124.0042
GM0542		yellow steel liner	1,2 ÷ 1,6 mm	.045" ÷ 1/16"	5 m	16.4'	124.0044

NOTE: At time of publication, the standard torch provided with Power i-MIG 275P is commonly known as the 36 series. This torch may be supplied by Binzel®, Trafimet®, or Innotec®. However the consumables and most parts interchange except the torch handle design and trigger. The widely used Euro-connector on the MIG torch also ensures that the customer can fit and install almost any other type MIG torch since most manufacturers offer torches with a Euro connector as an option. This list is provided as a general cross reference as a courtesy from Trafimet®, and does not guarantee that every variation or type is directly available from Everlast. In the left column, the OEM part numbers are listed, and in the far right column, the Binzel®, part number is listed as reference. These parts are interchangeable with the Innotec part number. You can find list of stocked consumables on the Everlast website. To cross reference to the Trafimet® part number, remove the EV prefix from the Everlast Part number.

SECTION 3

TROUBLE SHOOTING

NO	Trouble		Possible Cause	Solution
1	Unit is switched on, but the power light isn't on		Switch damaged.	Replace.
			Unit Fuse damaged.	Replace.
			Power breaker tripped.	Reset.
2	After welding machine is over-heating and the fan does not work		Fan damaged.	Check fan housing and fan. Replace if necessary.
			Fan power connector is loose.	Tighten wires, check for dislodged connectors.
3	When torch switch is pressed, no gas Flows		No gas in the gas cylinder.	Replace.
			Gas pipe leaks gas.	Resolve .
			Gas solenoid valve damaged.	Check and clean/replace.
			Torch switch damaged.	Repair or Replace.
			Control board damaged.	Inspect the circuit.
4	Wire-feeder does not work	Wire reel does not turn	Motor damaged/Fuse blown.	Check and Replace.
		Wire reel turns	Control circuit damaged.	Check the board.
	Wire reel turns	The tensioner is loose or wire slips on rollers. Wrong size drive roll. Wire is not mated in drive groove.	Increase tension. Check for proper drive roll size/type. Make sure wire is in groove not riding on top of the drive roller shoulder.	
		The drive roller doesn't fit the diameter of weld wire.	Change roller or wire size to match.	
		Wire Spool is damaged.	Change out wire spool.	
		Gun liner is jammed.	Repair or change it, clear wire from liner/clean liner with compressed air.	
		Contact Tip is jammed because of slag or burn back.	Clean or replace. If with Aluminum, increase tip size to next size.	
5	No arc, or no output voltage		Work clamp engaged in wrong connector.	Change polarity.
			Control circuit damaged.	Check the circuit.
6	Welding stops and warning light is on, Wire continues feeding but no arc		Self-protection has engaged.	Check over-voltage, over-current, over-temperature, lower-voltage and over-temperature. Allow unit to cool if over heated. If an OC, use a shorter wire stick out or smaller diameter wire or reduce power settings with large diameter wires. Check power plug for problems. If easily tripped the Resistor value too low. (Contact Everlast if OC is tripping regularly with normal settings.)
7	Welding Voltage/Current is uncontrollable		Potentiometer damaged.	Repair or Replace it.
			Control board damaged.	Check the circuit.
9	Intermittent Arc/ Wandering arc		Work Clamp is not secure or it is damaged. Too windy/breezy.	Check and/or Work Clamp, change position of clamp and attach direct to the work. Move out of wind.
10	Excessive spatter		Voltage too high too high arc force/ Too high wire speed. Too much torch angle. Wrong size nozzle	Lower voltage or increase wire speed. Check torch angle for less than 15° push or pull. Change arc force settings to reduce spatter. Change nozzle size.
11	Weld sooty or oxidized looking		Poor metal prep, poor gas flow, too much torch angle, wrong gas type, windy or breezy. Plugged nozzle	Thoroughly clean metal, check gas flow and reposition gun so gas flow is not creating turbulence. Move indoors if necessary. Reposition the welder so its fan will not blow on the weld area. Clean nozzle.
12	Bird nesting of the wire around the drive roll		Jammed gun liner, wire too soft (aluminum), gun hose is kinked or coiled too tightly. Too much tension / pressure on wire feeder .	Reduce wire feed tension so that drive will slip if it encounters too much resistance Check Gun and liner and replace if necessary. Straighten cable.
13	Wire feeds irregularly		Wrong drive roller or wrong size drive roller, too little tension on wire, wire in wrong groove.	Check and match wire size to groove size, increase tension on drive rollers. Check to make sure the wire is not riding on the shoulder of the drive roller.
14	Wire burns back and seizes in tip		Wrong contact Tip size or too much burn back time set.	Match tip size for wire diameter. Reduce burn back time. If using with aluminum, use tip designed for aluminum or use one size larger tip than the wire.
15	Nozzle arcs to work piece welding		Nozzle plugged with spatter	Check/clean nozzle and use a nozzle dip.
16	In Stick mode will not arc		Cables not connected, inverter issue	Check connections.
17	In Stick mode, the rod sticks		Arc force control is set too low, arc striking method is poor, wrong polarity, too low of amperage. Wet welding rods or wrong kind.	Check polarity. Increase arc force control. Change arc striking method. Increase amperage. Use fresh welding rods when possible.

